

# Installation/Owners Manual

# Patriot®

## Swing Gate Operator



**MADE IN THE USA**

# **PATRIOT Series** AUTOMATIC GATE OPERATORS

**This Patriot Gate Operator is intended to be installed on the four different classes of gate operators identified in the UL325 Standards.**

## **RESIDENTIAL VEHICULAR GATE OPERATOR – CLASS I**

A vehicular gate operator (or system) intended for use in garages or parking areas associated with a residence of one-to four single families.

## **COMMERCIAL/GENERAL ACCESS VEHICULAR GATE OPERATOR – CLASS II**

A vehicular gate operator (or system) intended for use in a commercial location or building such as a multi-family housing unit (five or more single family units), hotel, garages, retail store, or other buildings accessible by or servicing the general public.

## **INDUSTRIAL/LIMITED ACCESS VEHICULAR GATE OPERATOR – CLASS III**

A vehicular gate operator (or system) intended for use in an industrial location or building such as a factory or loading dock area or other locations not accessible by or intended to service the general public.

## **RESTRICTED ACCESS VEHICULAR GATE OPERATOR – CLASS IV**

A vehicular gate operator (or system) intended for use in a guarded industrial location or building such as an airport security area or other restricted access locations not servicing the general public, in which unauthorized access is prevented via supervision by security personnel.

## **Solar Friendly**

The Patriot system design and the accessories recommended are all Solar Friendly meaning that they require the least amount of energy possible to perform the job they were designed to do. The solar option allows you to install the gate operator in remote areas or in applications where you prefer to be solar charged. Solar charging provides additional isolation from lightning that might damage the unit via the AC power needed for the DC Adapter.

## **BATTERY REQUIRED FOR OPERATION** (*Battery not included*)

### **Recommended battery type:**

Battery 12-volt, Group U-1; sealed (maintenance free); 30 amp hour minimum.

Using a smaller amp hour battery may cause damage to the charging system.

The wiring harness has two 1/4" ring terminals to connect to battery posts.

**CAUTION: Do not install wet cell battery into control box; this type of battery usually has removable caps used for service and will vent into control box.**

The battery may be charged using the 120V AC Powered Transformer (PN 520009) **OR** the Patriot Solar Panel kit (PN 520028). Typically only one panel will be required. For information on what you can expect from a solar charged system see the solar charging section of this manual. Accessories that are added to your gate operator must be solar friendly accessories.

## **PLEASE READ THE ENTIRE MANUAL CAREFULLY PRIOR TO INSTALLATION.**

Study the entire Safety Section paying particularly close attention to the entrapment zones and install monitored entrapment devices to protect all entrapment zones identified. Installation by a Qualified Technician is recommended to verify all safety concerns are addressed.

© USAutomatic, LLC, 2025 rev. A

All rights reserved. No part of this manual may be reproduced by any means without the expressed written consent of the publisher.

USAutomatic Part # 720004



# TABLE OF CONTENTS

## INTRODUCTION

Entrapment Device Requirements and Zones.....	2-3
Important Safety Instructions and Safety Installation Information .....	4-5
Patriot Parts Inventory .....	6
Patriot Hardware Inventory .....	7
Actuator Dimensions .....	8
General Tool Requirements .....	8
Gate Qualifications/Applications .....	9
Proper Gate Design .....	10

## INSTALLATION STEPS

1. Mounting Site Review .....	11
2. Determine Opening Method (pull to open or push to open) .....	12
3. Determine Horizontal Mounting Location .....	13
4. Determine Best Method for Actuator Mounting Brackets - Pull to Open .....	14
Determine Best Method for Actuator Mounting Brackets - Push to Open .....	15
Determine Best Method for Actuator Mounting Brackets - Columns .....	16
5. Mount Support Bracket .....	17
6. Installing Actuator Mounting Tube - Pull to Open .....	18
Installing Actuator Mounting Tube - Push to Open .....	19
7. Installing Linear Actuator to Actuator Mounting Bracket .....	20
8. Install Gate Bracket to Linear Actuator .....	20
9. Install Gate Bracket to Gate .....	21
10. Install Patriot Control Box / Control Box Dimensions .....	21 - 22
11. Install Patriot Control Board .....	22
12. Installing Receiver, Battery Controller, and Entrapment Siren .....	23
13. Install Linear Actuator Cable .....	23
13a. Splicing Linear Actuator Cable and Dual Gate Cable .....	24
14. Installing Monitored Entrapment Protection Devices .....	25
Monitored Photo Eye (Type B1) Installation .....	25 - 26
Monitored Contact Edge (Type B2) Installation .....	27
Constant Pressure (Type D) Installation .....	27
15. Install Wiring Harness and Battery .....	28
16. Install Battery Controller Power Source (AC or Solar) .....	28 - 29
17. Connect Power Source to Battery Controller .....	30
18. Install Safety Signs .....	30
19. Connect Linear Actuator Cable to Control Board .....	30
20. Photo Eye Alignment .....	30
21. Operating Gate For The First Time.....	31
22. Making Retract and Extend Limit Adjustments .....	32
23. PWM Adaptive Soft Start / Stop Speed Control ASdjustment .....	33
24. Gate Delay Feature .....	33
25. Sensitivity Adjustment, Entrapment Alarm, and Auto Close Setting .....	34
26. Verifying Inherent Entrapment Protection System Operation .....	34 - 35
27. Patriot Control Board Information .....	36 - 39
28. Programming Transmitter, Receiver and Wireless Keypad .....	40 - 43

<b>PERIODIC SERVICE / EMERGENCY MANUAL RELEASE</b> .....	44
--	----

<b>ACCESSORIES</b> .....	45 - 47
--------------------------	---------

<b>TROUBLESHOOTING</b> .....	48 - 49
------------------------------	---------

## APPENDIX

A. Photo Eye - Vehicular Protection Only .....	50 - 51
B. USAutomatic Battery Controller .....	52

<b>WARRANTY</b> .....	53
-----------------------	----



# Entrapment Devices Required and Approved for Operation

Effective August 1, 2018 a vehicular swing gate operator must have provisions for, or be supplied with, at least two independent entrapment protection means for each direction of travel as specified in current UL325 standard Table 31.1. At installation, both entrapment protection devices must be installed and operational before gate operation is allowed. \*Exception allowed if no entrapment exist in one direction of travel then only 1 device is required, the other direction must have 2 entrapment protection devices active. The gate operator will monitor for proper operation before movement is allowed.

USAutomatic control boards utilize type A (Inherent entrapment protection system) as the first entrapment protection means identified. The second entrapment device identified must be a monitored Type B1 or Type B2 device that has been tested and approved with the gate operator. These devices are listed below.

USAutomatic control boards can monitor one photo eye (B1) for the open direction, one photo eye (B1) for the closed direction and two contact edges (B2) for the open/close direction. If additional entrapment devices are required the USAutomatic expansion module (part # 500015) is required

Type B1 - Non-contact sensor (photoelectric sensor or the equivalent). Identified as Normally Closed N/C contact switching.

Type B2 - Contact sensor (edge device or the equivalent). Identified as 10K resistor installed for presence monitoring.

Type D - Actuating device requiring continuous pressure to maintain motion of the gate.

## External entrapment devices approved for use are listed below

### Wired Contact Edge Type B2 Devices

**Manufacturer: ASO**

Models: Sentir Edge 95.25, 92.20, 85, 35.55, 65, 25.30, 25.45, 15.10

**Manufacturer: Miller Edge**

Models: MGR20, MGS20, ME120, MG020, ME112, MG123

### Wireless Contact Edge Type B2 Devices

**Transmitter Solutions: IGAZE RE KIT-UL**

**EMX Model: WEL-200K**

### Non-Contact sensors (photoelectric sensor or the equivalent) Type B1 Devices

**Manufacturer: USAutomatic, LLC**

Models: 550011, 550014

The entrapment zones illustrations on the following page defines the most common entrapment areas. It is the responsibility of the installer to identify all entrapment areas and install the appropriate compliant monitored entrapment device or devices to protect each area identified.

**USAutomatic recommends upgrading all systems to current UL325 standards.**

# ENTRAPMENT ZONES

The illustrations below are a guide to help identify entrapment areas for swing gate installations that must be protected. Other entrapment areas may exist and must be identified by the installer and protected by the appropriate entrapment protection device for the situation.

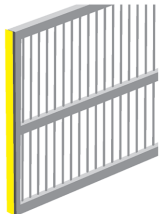
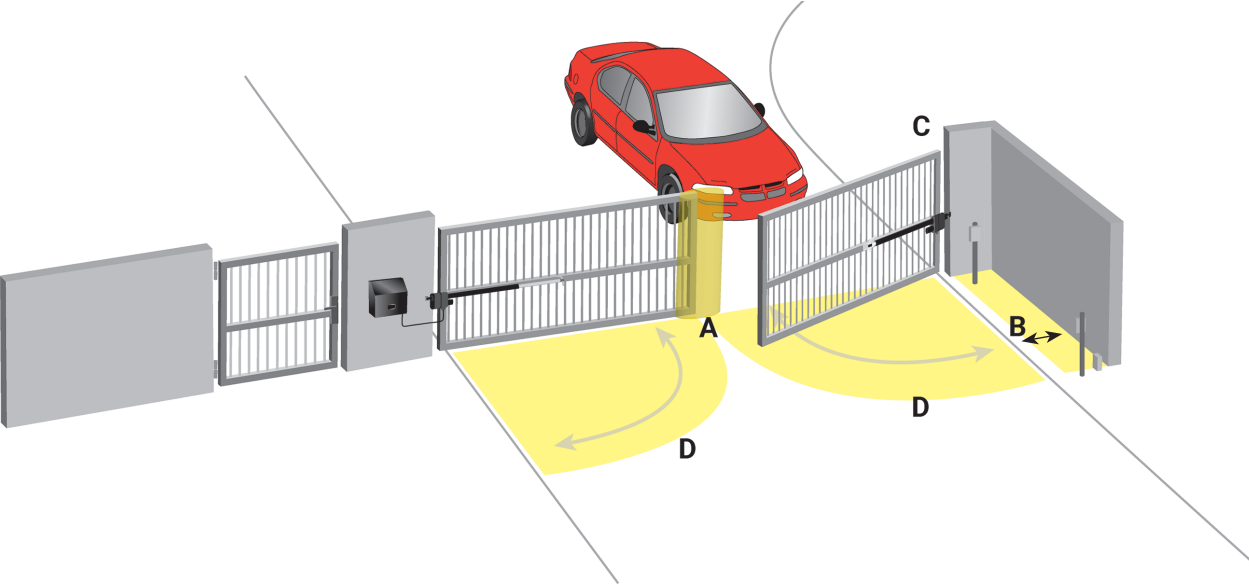

**Zone A** - Leading edge of gate where it meets a 2nd gate, stop post or passes a column or post corner. - recommended monitored entrapment protection type is B2 contact sensor or equivalent.

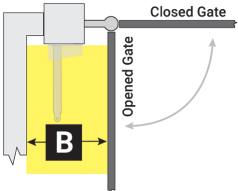

**Zone B** - Gate opens toward an immovable object with less than 16 inches (40.6 cm) of clearance - recommended monitored entrapment protection type B1 photo eye or equivalent. If space is less than 16" (40.6 cm), entrapment protection in this area is required.

(ASTM F2200: 7.1.1.1 and 7.1.1.2)

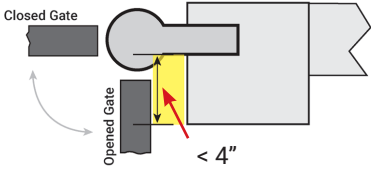

**Zone C** - If distance from center of hinge rotation point to corner of column, post or immovable object is greater than 4 inches (10.16 cm), recommended monitored entrapment protection type is B2 contact sensor or equivalent.

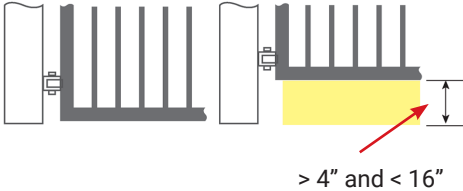

**Zone D** - If the bottom edge of a swing gate is greater than 4 inches (10.16 cm) and less than 16 inches (40.6 cm) above the ground at any point in its arc of travel, one or more contact sensors must be located on the bottom edge of the gate.

# IMPORTANT SAFETY INSTRUCTIONS

## WARNING - TO REDUCE THE RISK OF SEVERE INJURY OR DEATH

1. READ AND FOLLOW ALL INSTRUCTIONS
2. SAVE THESE INSTRUCTIONS!!
3. Always keep people and objects away from the gate. **NO ONE SHOULD CROSS THE PATH OF A MOVING GATE.**
4. Test the gate operator monthly. The gate **MUST** reverse on contact with a rigid object or stop when an object activates the non-contact sensors. After adjusting the force or the limit of travel, retest the gate operator. Failure to adjust and retest the gate operator properly can increase the risk of severe injury or death.
5. After all adjustments have been made to the sensitivity (current sense) circuit, secondary entrapment devices and all other external devices installed, the safety devices must be checked again. Failure to adjust and retest the gate operator can increase the risk of severe injury or death. A qualified technician should check these periodically for proper operation.
6. Use the manual release **ONLY** when gate is not moving, and power is disconnected.
7. **KEEP GATES PROPERLY MAINTAINED.** Tighten all bolts and grease hinges and pivot points.
8. **THE ENTRANCE IS TO BE USED BY VEHICLES ONLY.** The operator is intended for installation only on gates used for vehicles. Pedestrians must be supplied with a separate access opening. The pedestrian access opening shall be designed to promote pedestrian usage. Locate the pedestrian gate such that persons will not come in contact with the vehicular gate during the entire path of travel of the vehicular gate.
9. Never let children operate or play with gate controls or any other activation device. Keep remote control away from children.
10. The gate must be installed in a location so that enough clearance is supplied between the gate and adjacent structures when opening and closing to reduce the risk of entrapment.
11. Do not attempt to enter the gate area while the gate is moving. Wait until the gate comes to a complete stop.
12. **DO NOT ALLOW CHILDREN TO PLAY IN THE AREA OF THE GATE.**
13. Do not allow anyone to ride on the gate.
14. Operate the gate only when it is fully visible, free of persons or obstructions, and properly adjusted.
15. All controls must be located at least six feet away from the gate to eliminate the chance of the person operating the gate from coming in contact with the moving gate. Do not install external buttons, which can be used to operate the gate within the reach of children.  
*\*Exception: Emergency access controls only accessible by authorized personnel may be placed at any location in line-of-sight of the gate.*
16. Both Safety Signs must be installed, one on each side of the gate and visible in the gate area.

# SAFETY INSTALLATION INFORMATION

## **Install the gate operator when:**

- Operator is appropriate for the construction of the gate and usage class is correct for the installation.
- All exposed pinch points are eliminated or guarded.
- The gate is installed in a location where enough space is supplied between adjacent structures and the gate that when opening or closing the chance of entrapment is reduced.
- The gate is properly installed and moves freely in both directions. Do not over adjust the sensitivity adjustment to compensate for an improper gate installation.
- All hard wired sensors used for monitored entrapment protection devices and their wiring are installed in a manner which protects them from mechanical damage.
- The Reset button must be located in the line-of-sight of the gate. Activation of the reset button shall not cause the operator to start.

## **Non Contact Sensors - Type B1 - Photo Eyes or equivalent**

1. See entrapment zones for suggestions on placement of sensors.
2. Care shall be exercised to reduce the risk of nuisance tripping, such as when a vehicle trips the sensor while the gate is still moving.
3. One or more non-contact sensors shall be located where the risk of entrapment or obstruction exist, such as the area reachable by a moving gate.

## **Contact Sensors - Type B2 - Contact Edge or equivalent**

1. See entrapment zones for suggestions on placement of sensors.
2. One or more sensors shall be located on the inside and outside leading edge of a swing gate.
3. Additionally, if the bottom edge of a swing gate is greater than 4 inches (101.6mm) and less than 16 inches (406mm) above ground at any point in its arc of travel one or more sensors shall be located on the bottom edge.
4. A hardwired sensor shall be located and its wiring arranged so that the wiring between the sensor and the gate operator is not subjected to mechanical damage.
5. A wireless device such as one that transmits (RF) signals to the gate operator for entrapment protection functions shall be located where the transmission of the signals are not obstructed or impeded by building structures , natural landscaping or similar obstruction. A wireless device shall function under the intended end-use conditions.

## **Constant Pressure - Type D - Emergency switch or equivalent**

1. The gate operator controls must be placed so that the user has full view of the gate area when the gate is moving.
2. An automatic closing device (such as a timer, loop sensor, or similar device) shall not be employed. and no other activation device shall be connected.
3. Placard required shall be placed adjacent to the controls.



# PARTS INVENTORY

## All Operators include:

### Cabinet with Control Board

Part # 600020 Cabinet  
Part # 602020 Cover



Part # 500018 Control Board

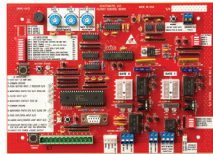

### Patriot Actuator

Part # 510001  
Single - 1 per  
Dual - 2 per



### Dual Gate Actuator Extension Cable 40'

Part # 630020  
Dual ONLY



### Battery Controller

Part # 520001



### DC Adapter

DC output @ 20 vdc - 1 amp  
Part # 520009  
with AC Models



### 10 Watt Solar Panel Kit

Part # 520028  
with Solar Models



### Safety Signs

Part # 601020  
2 per



### Photo Eye Kit with Batteries

Part # 550011  
1 set per



### LCR 2 Button Basic Transmitter

Part # 030210  
2 per



### LCR Low Current Dual Channel Receiver

Part # 030205



### Coax Antenna Extension Kit

Part # 030009



## Optional Accessories & LCR Items:

See accessories section for complete list and descriptions

USAutomatic WiFi App Module - Part# 030223

LCR 4 Button Basic Transmitter - Part # 030212

LCR 2 Button Premium Transmitter - Part # 030217

LCR 4 Button Premium Transmitter - Part # 030218

LCR Wireless Push to Operate Button - Part # 030215

LCR Basic Wireless Keypad - Part # 050500

LCR Premium Metal Wireless Keypad - Part # 050551

Premium Metal Hardwired Keypad - Part # 050700

Electric Gate Lock - Part # 070510

7 Day Timer - Part # 550015

CP-4 Free Exit Device - Part # 070305

Photo Eye Kit - Part # 550011

Metal Photo Eye Kit - Part # 550014

20 Watt Solar Panel Kit - Part # 520031

# HARDWARE INVENTORY

## BRACKETS

### Actuator Support Bracket 2"

Part # 610430

Single - 1 per  
Dual - 2 per



### Actuator Mounting Tube 2"

Part # 610104

Single - 1 per  
Dual - 2 per



### Gate Bracket

Part # 610107

Single - 1 per  
Dual - 2 per



### Manual Release Pin

Part # 620010

Single - 1 per  
Dual - 2 per



### Manual Release Pin Clip

Part # 620011

Single - 1 per  
Dual - 2 per



### Stainless Steel Bushing

Part # 610620

Single - 1 per  
Dual - 2 per



### Nylon Washer

Part # 610536

Single - 2 per  
Dual - 4 per



### 3/8" Bolt

Part # 610512

Single - 1 per  
Dual - 2 per



### 3/8" SAE Flat Washers

Part # 610516

Single - 2 per  
Dual - 4 per



### 3/8" SAE Nylon Insert Lock Nut

Part # 610518

Single - 1 per  
Dual - 2 per



### 1" Plastic Standoff

Part # 620008

Single - 7 per  
Dual - 8 per



### Cable Clamp

Part # 650020

Single - 1 per  
Dual - 2 per



### Secondary Entrapment Siren 12vdc

Part # 530015

1 per



### Charge Control Harness

Part # 630041

20 Amp Fuse  
1 per



### Screwdriver

Part # 610006

1 per



### Warning Placard

Part # 601015

1 per



## ACTUATOR DIMENSIONS

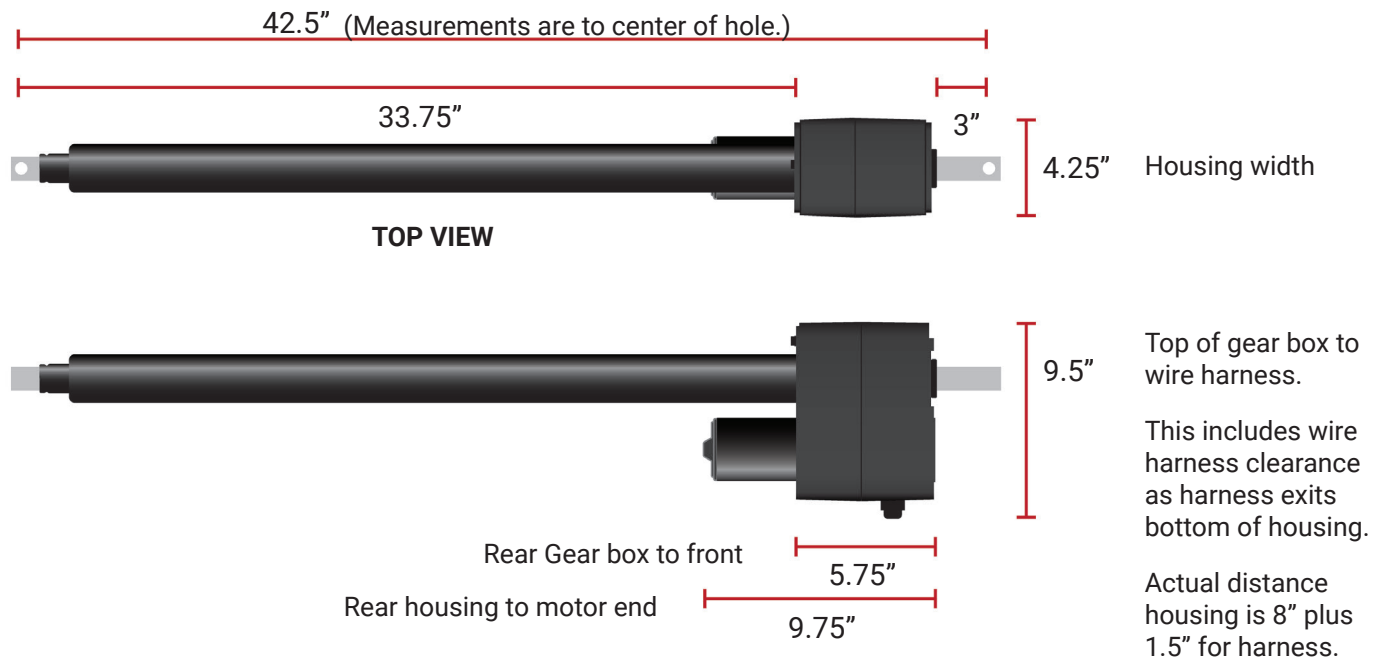

## GENERAL TOOL REQUIREMENTS

- SAE Standard wrenches & sockets
- Nut driver
- Level and tape measure
- Pliers
- Wire Cutters/Strippers
- Welder
- Drill and bits
- Drill adapter for socket attachment
- Hack saw

Welding is the recommended method of securing the linear actuator mounts to the gate and hinge post. Bolt on brackets require frequent service to keep tight. They must be very securely attached (i.e. carriage bolts with lock nuts and washers). Lag type bolts are not recommended. Loose or unstable linear actuator mounts will result in improper operation.

### IMPORTANT CAUTIONS:

- Do not perform any welding with the actuator cable plugged into the control board or the battery connected. Serious damage to the control board and/or battery may occur if attempted.
- Do not attempt to hold control box and drill mounting holes with components installed. This could damage the components.
- Always disconnect the battery power from the control board using the quick connect harness prior to wiring any devices to the control board.
- Do not test or operate without actuator securely attached to the gate. Serious damage to the actuator limit switch assembly may occur if attempted.

# GATE QUALIFICATIONS/APPLICATIONS

## GATE QUALIFICATIONS

The Patriot gate operator maybe installed on many different types of gates. Quality ball bearing hinges are recommended on all gates, especially on larger heavy steel gates.

The pictures below are provided as a guide to help understand the types of gates and size to provide many years of operation.



**Ornamental Iron**  
16 feet max length  
Max weight 800 lbs.



**Farm Gate**  
20 feet max length  
Max weight 250 lbs.



**Ranch Gate**  
16 feet max length  
Max weight 800 lbs.



**Chain Link Gate**  
16 feet max length  
Max weight 800 lbs.

## PROPER GATE DESIGN

### IMPORTANT- A GATE OPERATOR CANNOT OVERCOME A POORLY DESIGNED GATE.

Since the gate is a major component of the system, great care and concern must be given to the gate design. USAutomatic, LLC is not responsible for any damage to a gate on which the gate operator is installed. A poorly installed or misadjusted gate could be damaged. It is the responsibility of the installer to verify proper gate installation prior to operator installation. As a general rule, a gate, which is to be automatically operated, must be stronger and smoother than one operated manually.

- Does the gate swing smoothly without binds or excessive resistance?
- Swing gates should swing level and plumb to prevent the operator from having to lift the gate open or closed.
- Swing gates should not require a wheel to support them. Wheels create drag, which will cause operator problems. A wheel is generally a sign of a weak hinge system or a weak gate frame.
- Is the gate frame of substantial strength without excessive weight?
- Will the frame withstand normal wind load conditions without sway or vibration?
- Will the gate close correctly without being hand-guided or lifted to close?
- Are the hinges suited for an automatic gate operator? We recommend bearing type hinges to reduce friction drag.
- Will a reinforcement brace be required to attach the linear actuator to the gate or does a suitable cross member exist in the gate design?

**If any of these problems exist, they must be corrected to achieve a reliable automatic gate system.**

All Gates must have smooth bottom edges, no protrusions should exist. If gate hardware or sensors protrude, they must have smooth surfaces free of any sharp cutting edges that do not exceed  $\frac{1}{2}$  inch beyond the base of the gate. (ASTM F2200: 4.8)

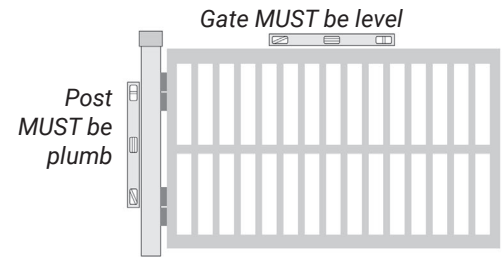

*Gate should not require a wheel for support.*



*Gate should not be unlevel due to weak frame.*



*Gate should not be unlevel due to unlevel post.*

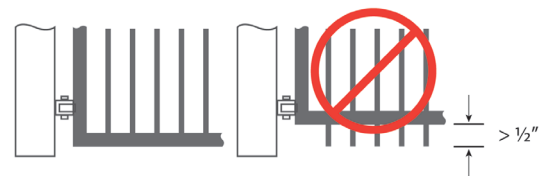
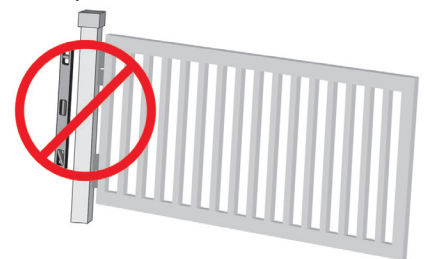

## 1 Mounting Site Review

Review the following items prior to installation and predetermine the solution to any problems which may exist:

1. Does sufficient space exist for mounting and future servicing of the operator and control box?
2. Which direction will the gate swing?
  - a. Will the gate operator pull the gate open to the inside (Pull to Open)?
  - b. Will the gate operator push the gate open to the outside (Push to Open)?  
(See Determine Opening Method Section)
3. Where and how will the actuator mounting brackets be secured to the hinge post and to the gate? (See Determine Actuator Mounting Brackets Sections)
4. How will the gate bracket be secured to the gate and will additional reinforcement be required?  
(See Determine Horizontal Mounting Location Section)
5. Where will the control box be mounted to support the weight of the battery and other components and can it be located within 8 feet to prevent splicing of the linear actuator cable?  
(See Install Patriot Control Box Section)
6. For AC Charged System - How far away is the 120 VAC receptacle for the DC Adapter?  
The DC Adapter is supplied with 10 feet of cable. If extension is needed use power source cable Extension Kit part #630038. See Power Source Cable Extension chart for identifying the wire size needed for the distance required. DC Adapter must be installed indoors or in a raintight enclosure. The DC Adapter should not be exposed to moisture.
7. For Solar Charged System - Where will the solar panel mount so that optimum sunlight is received? Solar panel is provided with 15 feet of cable, If extension is needed use power source cable Extension Kit part #630038 or 75' Solar Extension part #520016. See Power Source Cable Extension chart for identifying the wire size needed for the distance required. Solar panel typically needs to be facing a South or Southwest direction.
8. How will accessory control wiring, if any, be brought to the control box? Knock outs are provided in control box bottom for conduit.
9. Have all safety concerns been addressed? Study the Safety Section and Entrapment Zones for more information.
10. Identify entrapment areas. Determine the appropriate UL325 compliant monitored entrapment device/devices that will be used to protect all entrapment areas.
11. Is there enough space beneath the linear actuator for the cable so that damage to the cable does not occur? Actuator must not be installed with cable on the top side of the actuator.  
**Cable must exit actuator on the bottom side to prevent water from entering housing. See horizontal mounting location section.**



## 2 Determine Opening Method

(pull to open or push to open)

### Pull to Open Installation

This installation method is the most common where the gate swings into the property and the operator **pulls** the gate open.

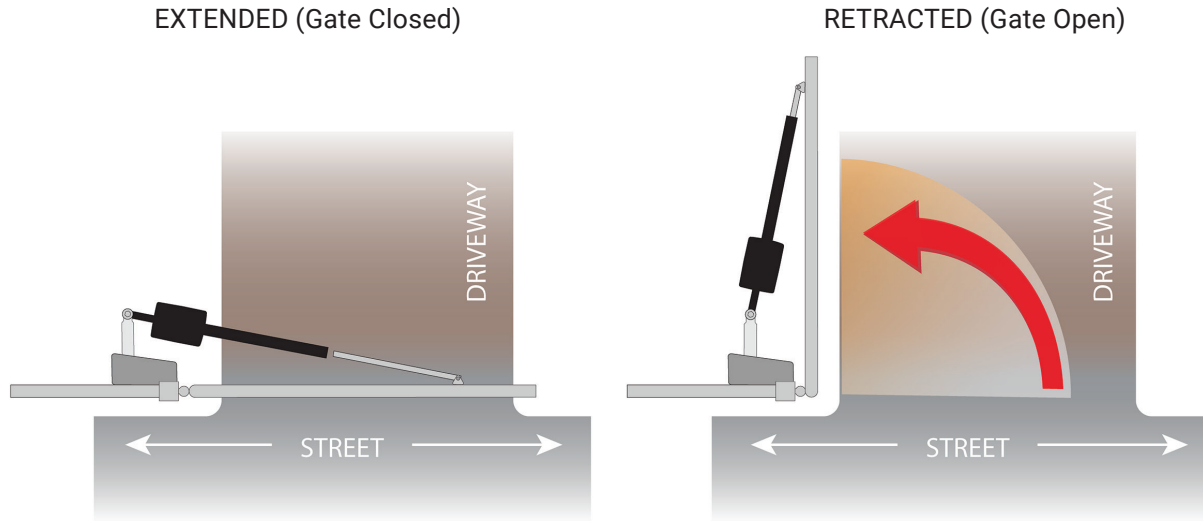

### Push to Open Installation

This installation method is commonly used where the drive slopes upward into the property and the operator **pushes** the gate open. The gate swings outward away from the property.

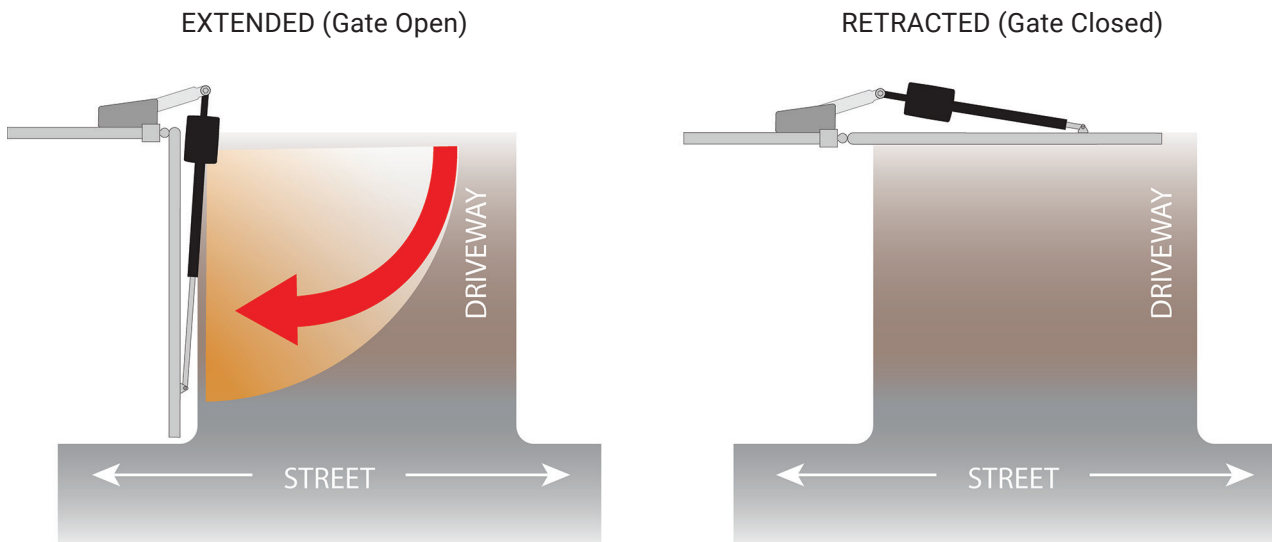

### 3 Determine Horizontal Mounting Location

Now that the type of installation (pull to open or push to open) has been determined, the vertical height position of the support bracket and actuator mounting tube must be determined. Refer to these examples to determine the mounting location of the gate bracket on the gate, which is needed to determine the location of the actuator mounting tube.

The actuator delivers force on the gate when operating. Aligning the actuator mounts with a horizontal gate frame member is the best choice. (as shown here)

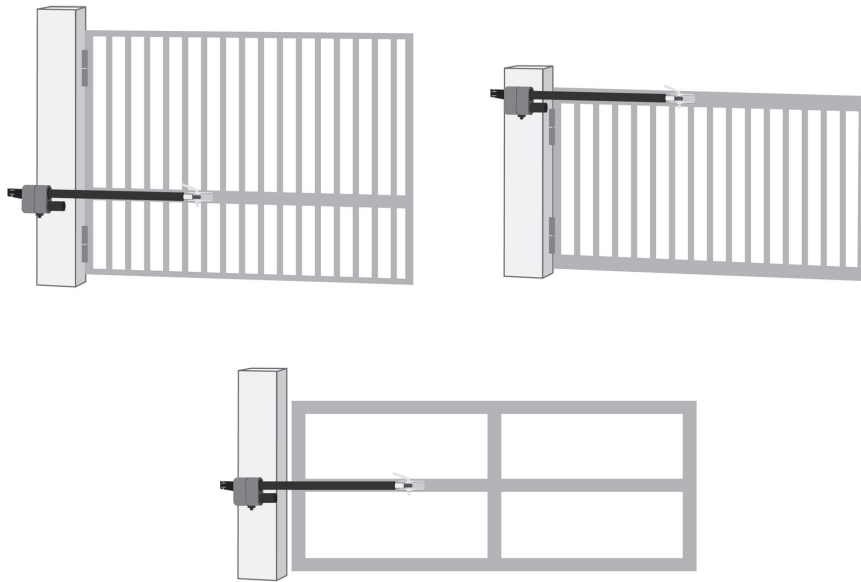

Installation of a horizontal brace may be necessary to prevent damage to vertical gate pickets.

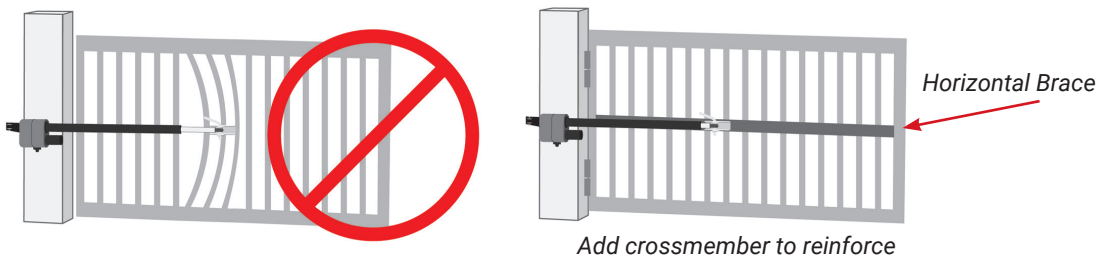

Avoid mounting actuator on bottom rail of gate. Unit will be more likely to be damaged by flooding and will be difficult to service and adjust.

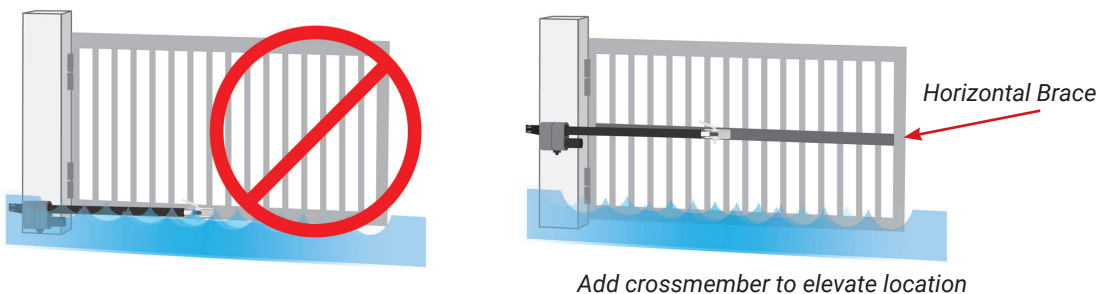

# 4a Determine Best Method for Actuator Mounting Brackets - PULL TO OPEN

Study the examples below and determine the best method for your gate. The examples below are for left hand installations. Reverse for right hand installations.

## Square Post

Actuator support bracket mounted horizontally on hinge post

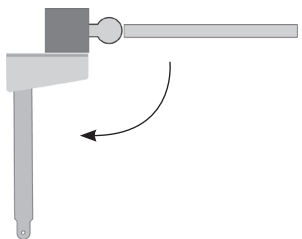

Actuator support bracket mounted horizontally on fence rail

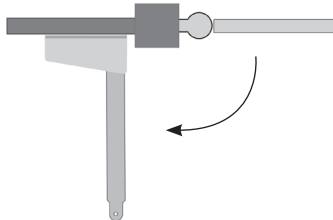

Actuator support bracket mounted vertically on hinge post

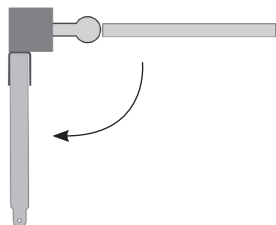

Actuator support bracket mounted vertically opposite hinge

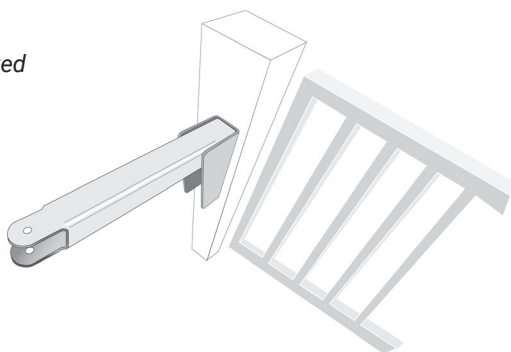
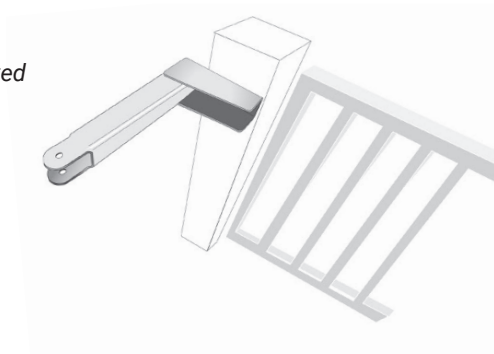
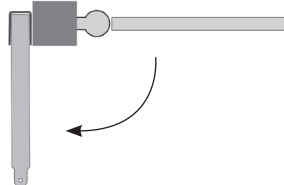

3D Example

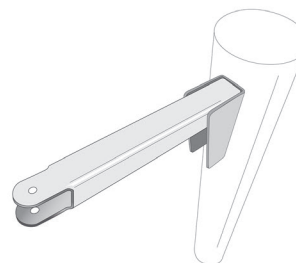

## Round Post

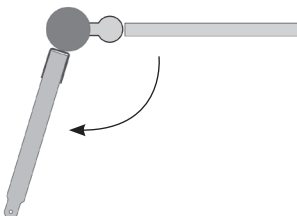

Actuator support bracket mounted vertically on hinge post

## Wood or Aluminum Post

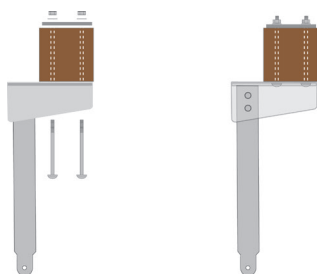

Drill through mounted.

Drill through post and bracket. Use carriage bolts with back plate. (not included)

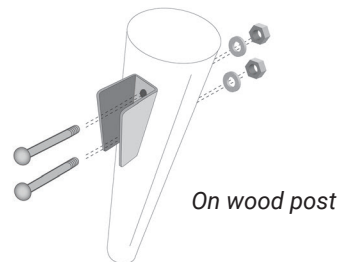

## 4b Determine Best Method for Actuator Mounting Brackets - PUSH TO OPEN

Study the examples below and determine the best method for your gate. The examples below are for left hand installations. Reverse for right hand installations.

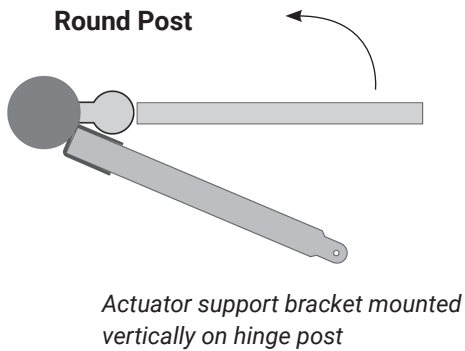
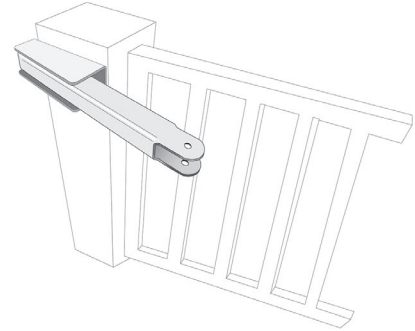
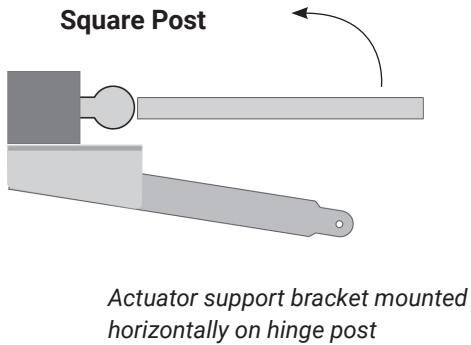

3D Example

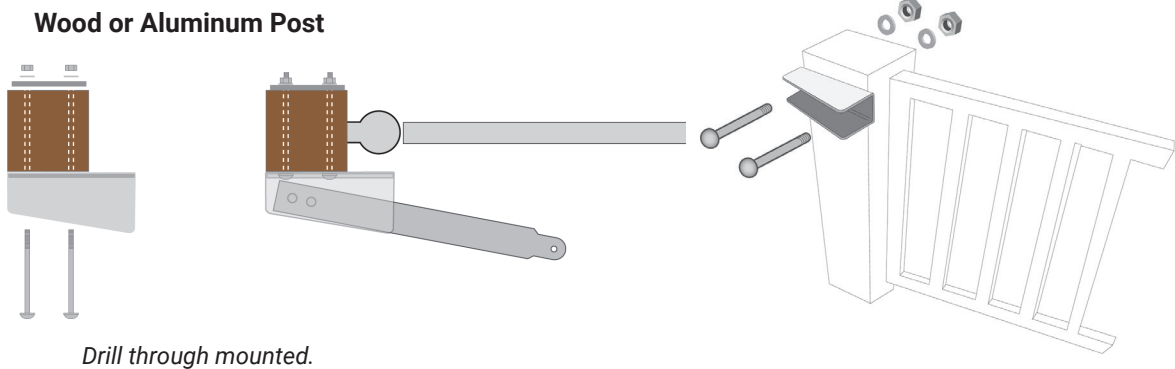
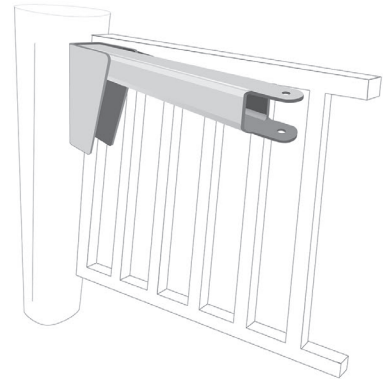

## 4c Determine Best Method for Actuator Mounting Brackets - COLUMNS

Dimensions shown are for 90° - 95° opening.

### New Construction

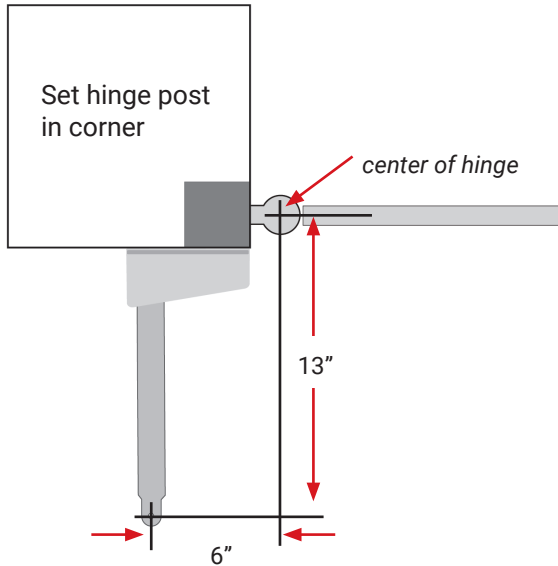

### Existing Columns

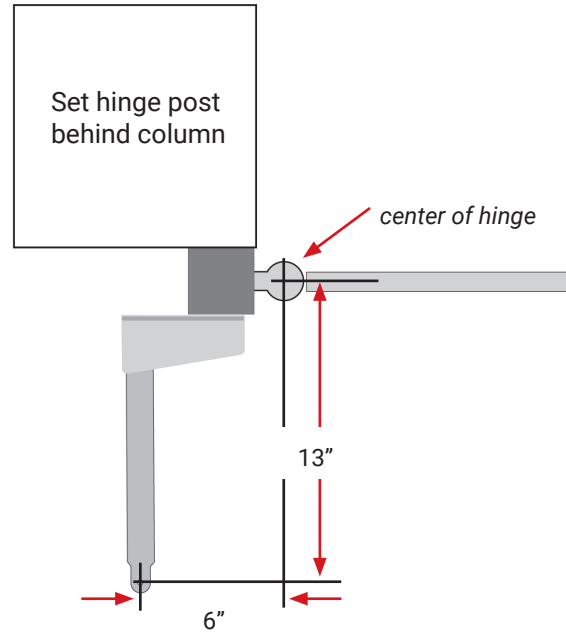

### Entrapment Area

Avoid designing a system that places the hinge center rotation point more than 4 inches from the corner of the column. This will create an entrapment point between the gate and the column when the gate is moving in the open direction.

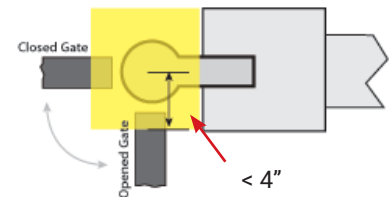

## 5 Mount Support Bracket

Now that you have determined the method and the vertical mounting location of the Actuator Support Bracket, mount the support bracket in alignment with predetermined horizontal frame member as per the following examples.

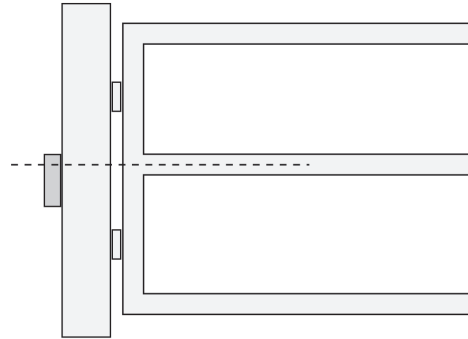
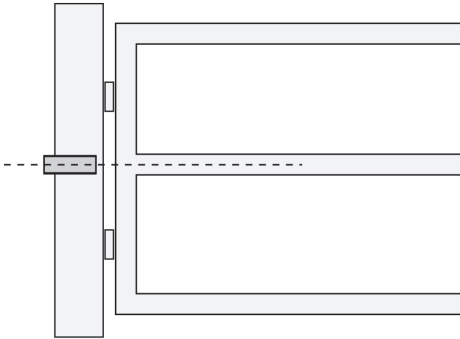

**Bracket must be level in all directions.**

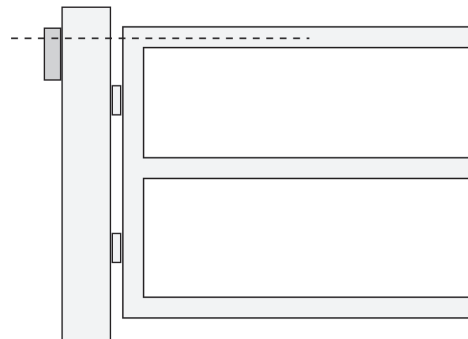
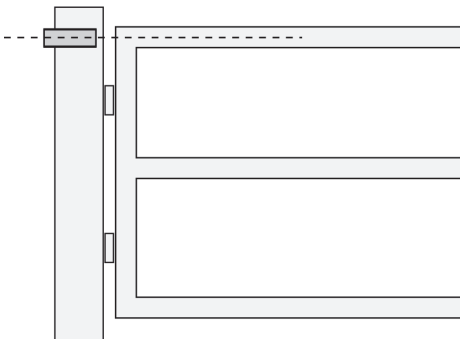

**DO NOT mount support bracket in a manner that obstructs gate movement or creates a pinch point.**

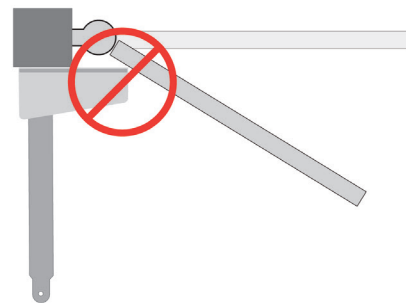

## 6a Install Actuator Mounting Tube - PULL TO OPEN

Cut Actuator Mount Tube to proper length. Weld to support bracket.  
 (See table below for desired dimensions.)

The actuator mounting tube will need to be cut so that the  $\frac{3}{8}$ " hole location matches the dimensions for a pull to open system.

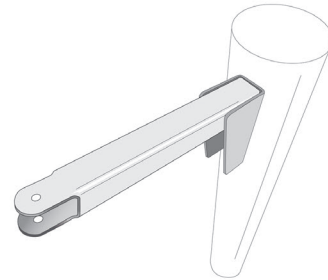
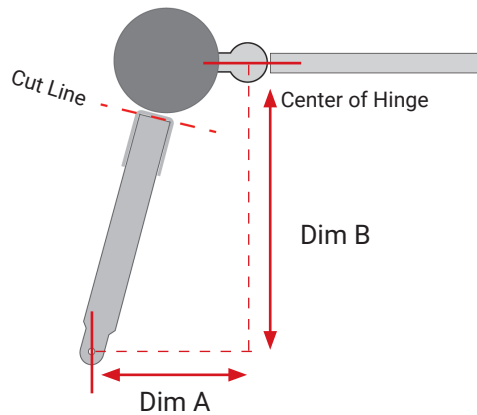
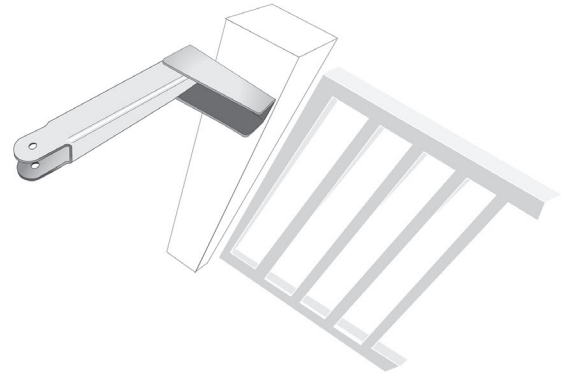
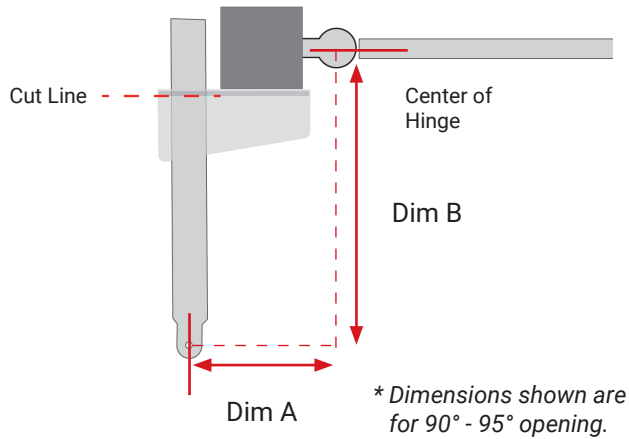

PULL TO OPEN - Actuator Hinge Mounting Tube Installation Dimensions		
Gate opening in degrees	Ranger HD Dimension A	Ranger HD Dimension B
90 degree opening	6"	13"
100 degree opening	7.5"	12"
105 degree opening	9"	10.5"
120 degree opening	11"	8"

## 6b Install Actuator Mounting Tube - PUSH TO OPEN

Cut Actuator Mount Tube to proper length. Weld to support bracket.  
 (See table below for desired dimensions.)

The actuator mounting tube will need to be cut so that the  $\frac{3}{8}$ " hole location matches the dimensions for a push to open system.

Before welding in place, ensure the actuator mounting tube is level in all directions and  $\frac{3}{8}$ " pivot hole location on actuator mounting tube is at proper point per the dimension chart for the type of installation being performed

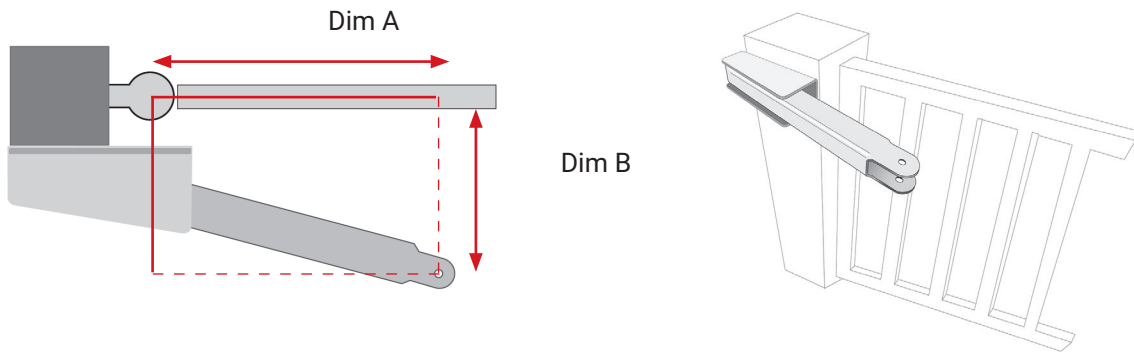

\* Dimensions shown are for 90° - 95° opening.

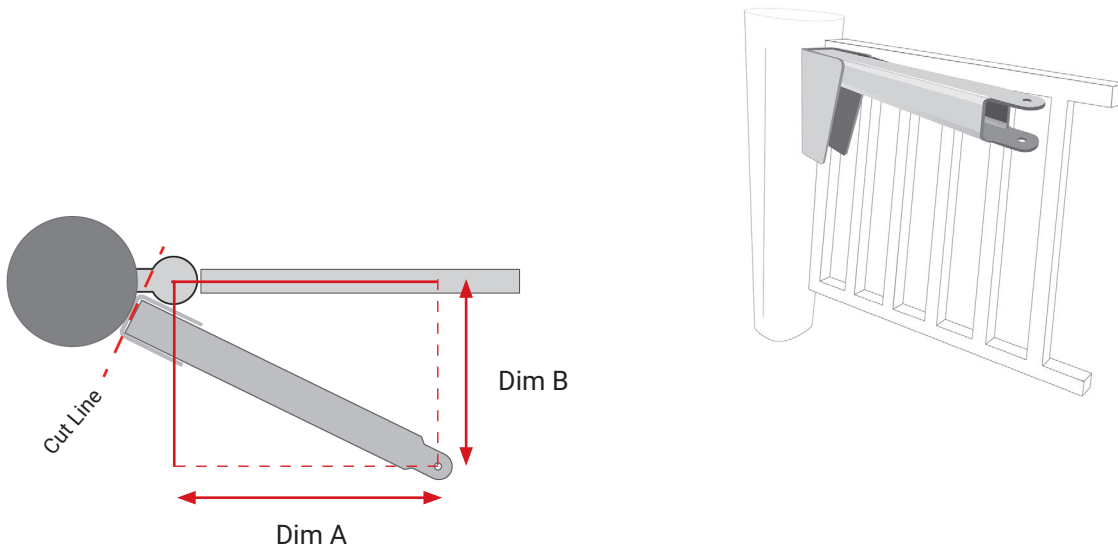

PUSH TO OPEN - Actuator Hinge Mounting Tube Installation Dimensions		
Gate opening in degrees	Ranger HD Dimension A	Ranger HD Dimension B
90 degree opening	11"	6"
100 degree opening	13"	6"
110 degree opening	14.5"	6"

## 7 Install Linear Actuator to Actuator Mounting Bracket

The linear actuator should be mounted to the actuator mounting bracket using the provided hardware. Assemble as shown below. Tighten lock nut securely.

**Note:** The linear actuator may be installed UPSIDE down to facilitate limit adjustments at this point. Then after all adjustments have been made, install linear actuator correctly with cable pointing toward the ground. **Failure to do so will allow water to enter the rear housing and damage the limit assembly.**

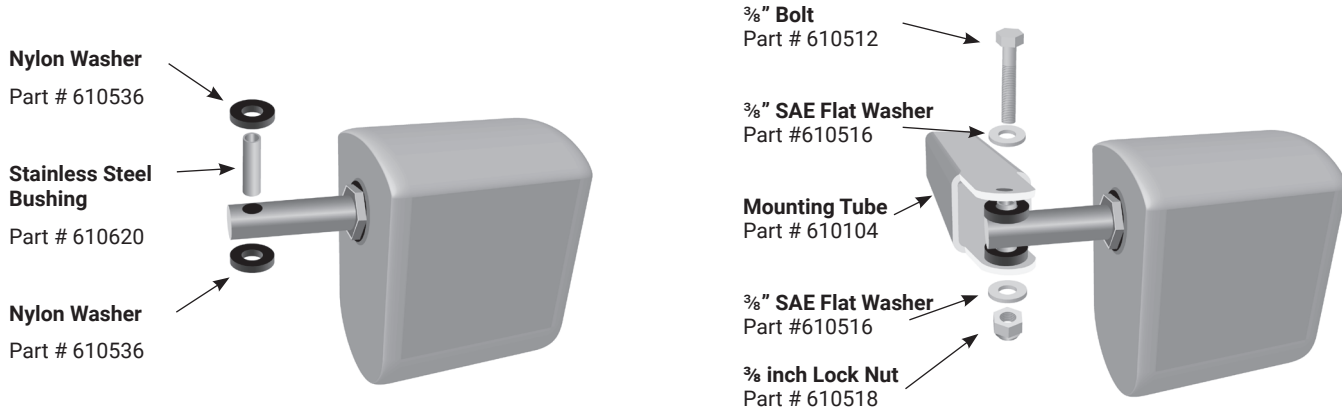

## 8 Install Gate Bracket to Linear Actuator

Install gate bracket and manual release pin to linear actuator as shown.

**DO NOT** operate the actuator before performing all installation steps. There is normally no need to extend the actuator before all installation steps are complete. If you must operate the actuator, ensure that the extension screw does not rotate while operating to avoid possible actuator limit assembly damage.



## 9 Install Gate Bracket to Gate

### IMPORTANT/CAUTION

If welding, do not have the actuator connected to gate, gate post, or Control board at any time during welding process.

#### (PULL TO OPEN INSTALLATION ONLY)

The linear actuator was shipped from the factory set to the fully retracted position.

The steps below will determine where the gate bracket is to be installed on the gate.

1. Swing gate to the fully open position.
2. Swing linear actuator around in a level position to meet the fully open gate. The contact point is where the gate bracket should be installed on the gate.
3. Weld or bolt the gate bracket to the gate.
4. Connect actuator to gate bracket at this time and install manual release pin.

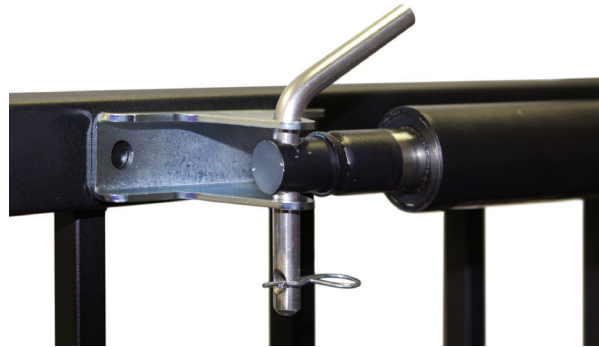

#### (PUSH TO OPEN INSTALLATION ONLY)

The linear actuator was shipped from the factory set to the fully retracted position.

The steps below will determine where the gate bracket is to be installed on the gate.

1. Swing gate to the fully closed position.
2. Swing linear actuator around in a level position to meet the fully closed gate. The contact point is where the gate bracket should be installed on the gate.
3. Weld or bolt the gate bracket to the gate.
4. Connect actuator to gate bracket at this time and install manual release pin.

## 10 Install Patriot Control Box / Control Box Dimensions

The control box should be securely mounted to an object or surface strong enough to support the weight of the box, battery and other components to be installed. The box can be welded or screwed to a suitable mount. The most common mounts are to an adjoining fence panel or wall. Holes can be drilled into the control box for mounting prior to component installation.

With all components properly installed, the battery compartment's maximum usable space is 15" wide x 6 3/4" deep x 8" tall. This space will easily accommodate the recommended 30 to 35 amp hour battery (see Page 28, Step 15 for battery details). Larger batteries that conform to the above dimensions may be used as well. However, you may need to install larger ring terminals to connect the wiring harness to the larger battery's terminals. **In all cases the battery must be a non-vented (sealed), maintenance free battery.**

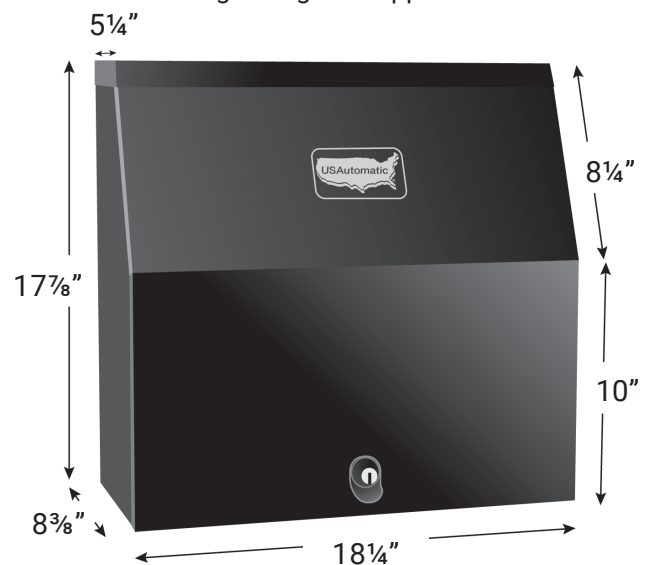

## 10 Install Patriot Control Box (cont.)

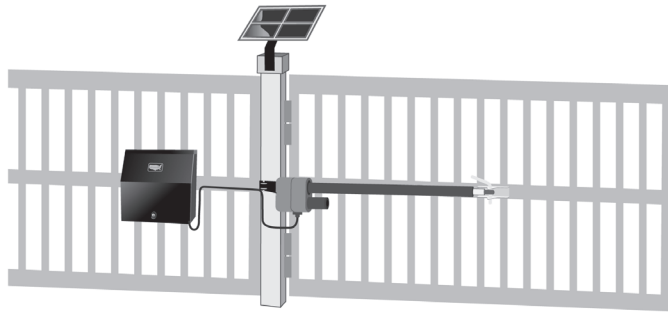

When deciding where to mount the control box remember the actuator cable is 8 feet in length. If possible, mount the control box in a location that will allow the cable to be neatly routed. If it must be longer than the 8 feet, see Splicing Actuator Cable step 13a. Also avoid choosing a mounting location that is near sprinklers.

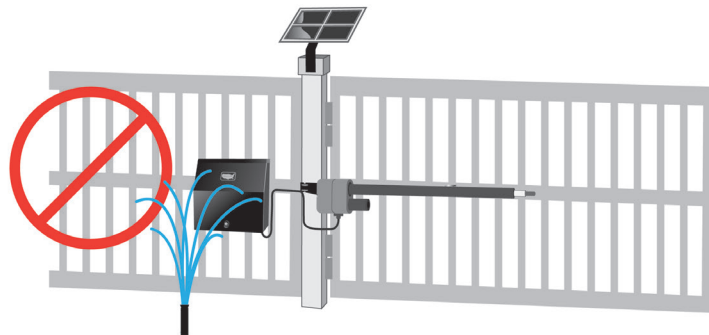

We have provided knockouts for conduit fittings in the control box bottom right corner. We highly recommend using conduit for all accessory wiring entering the control box. Determine which knockouts are to be used and punch out at this time.

NOTE: One 1 1/4" knockout is already removed for a single gate installation or for the closest gate on a dual gate installation.

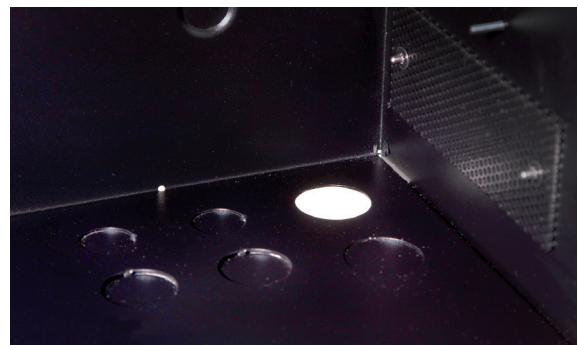

## 11 Install Patriot Control Board part #500018

Remove Patriot Control Board from cardboard package and mount on nylon standoffs. Push lightly at each corner to lock board in place.



## 12 Installing Receiver, Battery Controller, and Entrapment Siren

Before installing the Battery Controller into the control box connect the wiring harness to the battery controller.

Using the 2 nylon nuts provided install Battery Controller into control box in the upper left corner as shown. Use a ¼" nutdriver to secure.

Install the receiver into the control box below the Battery Controller using the 2 nylon nuts provided as shown. Use a ¼" nutdriver to secure.

Connect coax cable to receiver and install antenna bracket and antenna.

Connect the receiver's 4 pin plug to J11 on the control board as shown.

Install Entrapment Siren into the control box using the 2 nylon nuts provided as shown. Use a ¼" nut driver to secure. Connect the Siren power leads to the J4 Terminal as shown.

This siren is also used for low battery notification.

Black - COMMON GND  
Red - OUTPUT 12V

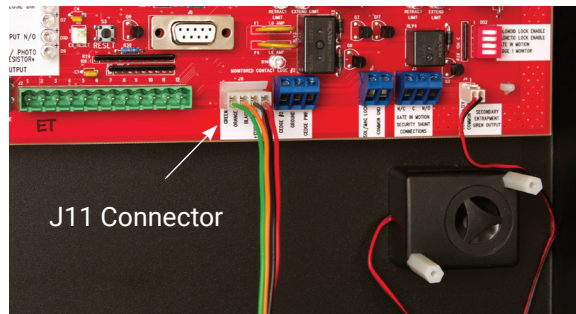
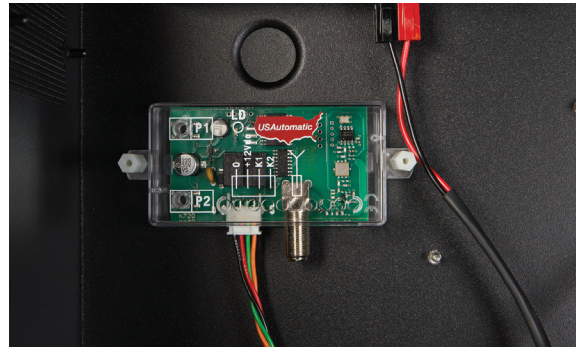

## 13 Install Linear Actuator Cable

The linear actuator is supplied with 8' of cable. Care should be taken to protect the cable from damage that might be caused by animals, lawn equipment etc.

Route the cable into the control box bottom, snap in 1 ¼" plastic grommet, and secure cable to control box using the supplied cable clamp and nylon nut provided as shown. Use a ¼" nutdriver to secure.

**DO NOT plug into control board at this time.**

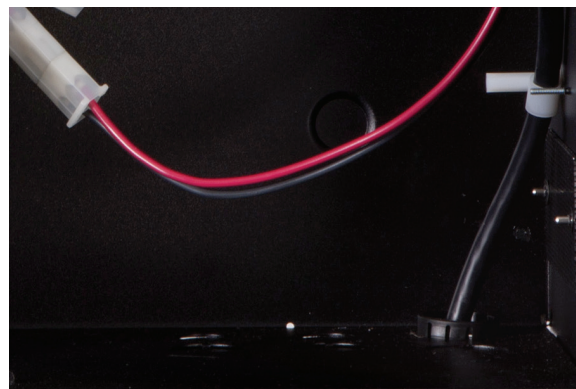

## 13a Splicing Linear Actuator Cable or Installing 2nd Linear Actuator Cable for Dual Gate System.

When adding an extension cable to a single gate actuator cable or when installing a second gate actuator for Gate 2, the 8 foot actuator cable must be cut and spliced in the following manner.

### Once actuator has been installed:

1. Locate the linear actuator 8 pin connector. Measure 18 inches from the connector end and cut the black cable. See Figure
2. Save this 8 pin connector and pigtail cable for step 8.
3. Install a rain tight junction box above ground on the Gate 2 hinge post below or near the actuator.
4. Install the extension cable from the junction box at Gate 2 to the control box. Route the cable through the bottom of the junction box and the control box. Cut the cable longer than needed for future needs and ease of servicing.

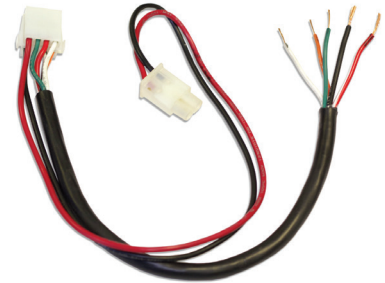

**NOTE: The Dual Gate Opener system includes 40 ft of extension cable. If the distance between the junction box and the control box exceeds this distance it is recommended to purchase a cable that will not require additional splices in the cable. USAutomatic Part# 630010 can be custom ordered and purchased in any length. Never make underground splices as moisture in connections will definitely cause system malfunctions.**

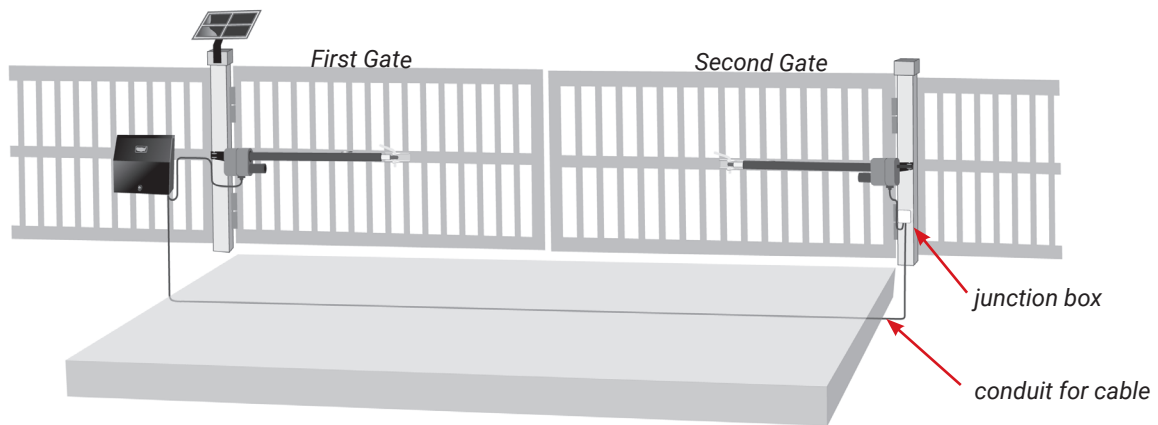

5. Route the linear actuator cable into the junction box through the bottom of the box and determine length. Allow ample slack in the cable for actuator movement when opening and closing the gate. Cut cable longer than needed for future servicing.
6. Remove at least 2 inches of the exterior black jacket on both cables routed into the junction box. Strip back approximately 1/2 inch of insulation from all wires. Connect the wires from each cable, matching color to like color with wire nuts. Pull firmly on all wires to be sure all connections are tight.
7. Install rain tight cover on junction box.
8. Remove at least 2 inches of the exterior black jacket on the pigtail cable (saved from step 2) and on the remaining end of the extension cable previously routed into the control box (step 4). Strip back approximately 1/2 inch of insulation from all wires. Connect the wires from each cable, matching color to like color with wire nuts. Pull firmly on all wires to be sure all connections are tight.
9. Do not plug into control board at this time.

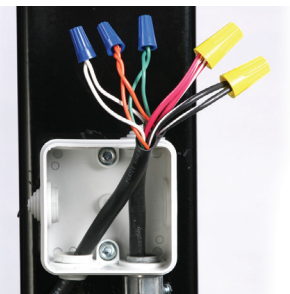

**IMPORTANT: The length of the extension cable should be as short as possible. Cable should be installed in conduit from control box to junction box.**

## 14 Installing Monitored Entrapment Protection Devices

When the installation requires more than 2 monitored contact edges or 2 monitored photo eyes, the Monitored Entrapment Device Expansion Modul must be installed. (USAutomatic Part# 500015)

### 14a Monitored Photo Eye (Type B1) Installation for Entrapment Protection ONLY. (page 3)

Connect wires per the table below or the [drawing on following page](#).  
All wiring should be done with power disconnected from control board.

Installer must determine if the photo eye is being used for gate Open or Close direction protection from entrapment. This must be done to determine where the N/C contact wire is going to be connected. Once known use the chart below or diagram on following page for wiring.

The corresponding dipswitch must also be turned ON as indicated on page 31.

Closed direction dipswitch DS1 switch 8.

Open direction switch DS1 switch 7.

Photo Eye wiring for Entrapment Device Protection	
Photo Eye Connections	Patriot Control Board Connections
Power +12 vdc	J2 pin 12
Power ground / 0	J2 pin 2 or pin 7
Common	J2 pin 2 or pin 7
N/C contact Closed Direction	J2 pin 8
N/C contact Open Direction	J2 pin 4

During installation +12 vdc power is required to align the photo eye beam.

Set control board DS1 dipswitches as follows for the installation:

Control Board Dipswitch Settings for Installation	
DS 1 switch 3	OFF – press down on the left hand side
DS 1 switch 4	OFF – press down on the left hand side
DS 1 switch 10	ON – press down on the right hand side

Install the photo eye at this time. Once power is applied to the system, verify alignment. Step 20.



## Wiring Photo Eyes to the Control Board

**NOTE: Photo eye operation requires DS1 switch 10 to be turned "ON"**

### Closed Direction Wiring

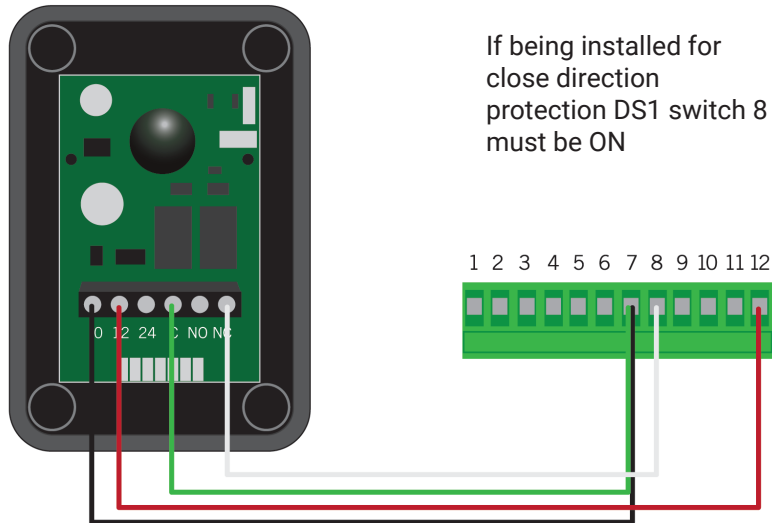

If being installed for close direction protection DS1 switch 8 must be ON

Photo eye "0" connects to J2 green plug pin 7.  
Photo Eye "12" connects to J2 pin 12  
Photo Eye "C" connects to J2 pin 7  
Photo Eye "NC" connects to J2 pin 8

### Open Direction Wiring

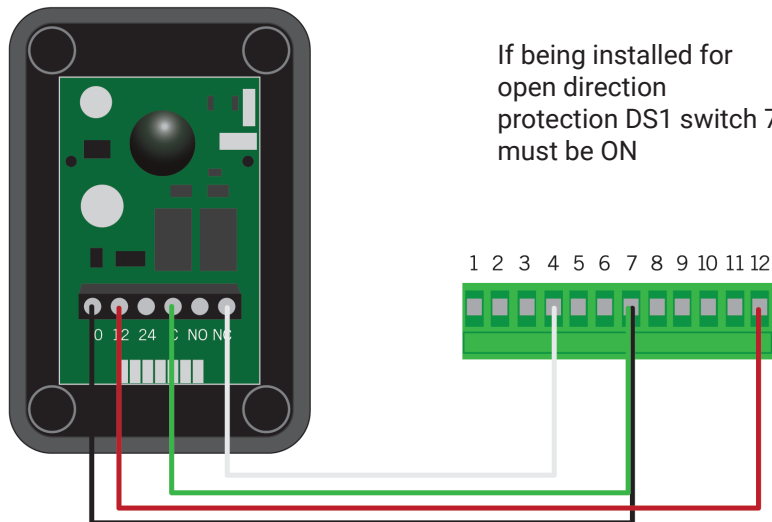

If being installed for open direction protection DS1 switch 7 must be ON

Photo Eye "NC" connects to J2 pin 4

## 14b Monitored Contact Edge (Type B2) Installation for Entrapment Protection ONLY.

Connect wires per the table below: All wiring should be done with power disconnected from control board. Contact edge must have 8.25K or 10K ohm resistor built into device.

Contact Edge #1 wiring for Entrapment Device Protection	
Contact Edge Connectons	Patriot Control Board Connections
N/O connection	J2 pin 6
Common	J2 pin 2 or pin 7
Contact Edge #2 wiring for Entrapment Device Protection	
Contact Edge Connectons	Patriot Control Board Connections
N/O connection	J7 pin 3
Common	J7 pin 2 or J2 pin 2 or pin 7

### Installing Wireless Contact Edge (Type B2) Receiver

Contact Edge #1 wiring for Entrapment Device Protection	
Contact Edge Connectons	Patriot Control Board Connections
N/O connection	J2 pin 6
Common	J2 pin 2 or pin 7
Contact Edge #2 wiring for Entrapment Device Protection	
Contact Edge Connectons	Patriot Control Board Connections
N/O connection	J7 pin 3
Common	J7 pin 2 or J2 pin 2 or pin 7

## 14c Constant Pressure (Type D) Installation

Connect wires per the table below: All wiring should be done with power disconnected from control board. The included warning placard must be installed by the control switch.

Type D wiring for Emergency / Constant pressure Operation	
Constant Pressure Switch N/O type	Patriot Control Board Connections
N/O connection	J5 pin 1
Common	J5 pin 2



## 15 Install Wiring Harness and Battery

The recommended battery for most installations is a 12 volt Group U1 maintenance free battery, 30 to 35 amp hours. This type battery is commonly known as a lawn tractor or wheel chair battery.

The wire harness is supplied with two ¼" ring terminals for connection to the battery. Connect the wire harness red wire to the positive post of the battery and the wire harness black wire to the negative post of the battery as shown.

Connect the actuator 2 wire connector (or connectors if dual gate) to wire harness as seen in the image here.

Plug the J2 accessory plug into the control board at this time.

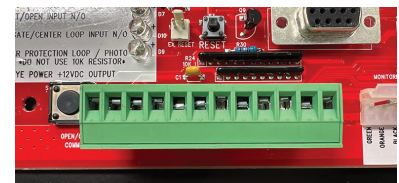
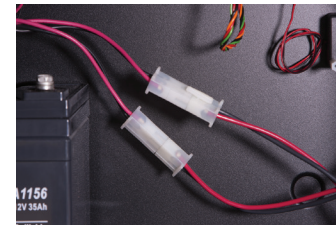

## 16 Install Battery Controller Power Source (AC or Solar)

The USAutomatic battery controller can be powered by an DC transformer supplied with AC Models OR a solar panel supplied with Solar models. The DC Transformer and the Solar Panel are equipped with a DC plug for easy connection to the battery controller.

### 16a AC Charged System

The AC model gate operator comes with a low voltage transformer which plugs into the battery controller and can easily provide 575 cycles of operation a day without decreasing the battery charge. In the event AC power goes out the operator will operate for weeks on the battery (if cycles per day are below 20) before needing service. Accessories connected to the operator are critical. Always use Solar Friendly accessories to help avoid premature battery failure in cases of power outages.

The unique design of the charging system allows the transformer to be installed away from the gate area if needed. This means that on AC charged systems, the transformer's low voltage wire can be extended avoiding the expense of having an electrician install 120 VAC at the gate area.



DC Adapter or Solar Extension Wire Size Chart	
0 to 100 ft	101 to 250 ft
18 gauge wire	16 gauge wire

NOTE: Transformer is not designed to get wet. Likewise, all splices should be made in a dry enclosure or outdoor box.

**NOTE: USAUTOMATIC RECOMMENDS A GROUND FAULT CIRCUIT INTERRUPTER (GFCI) RECEPTACLE AND SURGE PROTECTION ON ALL AC CHARGED INSTALLATIONS.**

## 16b Solar Charged System



The solar option allows you to install the gate operator in remote areas or in applications where you prefer to be solar charged. Solar charging provides isolation from lightning that might damage the unit via the AC power needed for the DC Adapter. The use of solar friendly accessories will help prevent premature battery failure.

The Solar model Patriot gate operator comes with a 10 watt solar panel and is designed to provide enough cycles a day for most installations without needing more than one solar panel. Care must be taken to ensure the solar panel has full sun throughout the day; partial sun will give partial results. If no sun is present then a solar system is not practical no matter how many panels might be installed. The solar panel must be kept clean and in full sunlight.

The location of the solar panel is critical for proper battery charging. The panel needs to face a South to Southwest direction and be installed at the angle of the supplied solar panel bracket. For proper operation the panel must have unobstructed sun. Even a small amount of shade will cause the Solar Panel to cease charging. Something as tiny as a fingertip shadow will affect the Solar Panel.

Solar panel may be moved up to 200 feet from the control box to achieve adequate sunlight. See power source cable extension chart on previous page for proper wire size. For convenience use the USAutomatic 75' Cable Kit Part #520016.

See Region Map below to determine cycles that can be expected. These numbers are based on a basic system with the standard 10 watt solar panel. Adding solar friendly accessories will not have any great affect on the numbers stated. Using other accessories can cause premature battery failure.

### GATE CYCLES PER DAY SOLAR CHARGED SYSTEM (10 Watt Solar Panel Kit Part #520028)

Model Type	ZONE 1	ZONE 2	ZONE 3
Patriot I Single Gate	35 cycles per day	55 cycles per day	95 cycles per day
Patriot II Dual Gate	18 cycles per day	28 cycles per day	48 cycles per day

Region 1 covers the area of the country receiving the least amount of solar radiation. On average the amount of charge time is 2.5 hours in region 1, 3.5 hours in region 2 and 5.5 hours in region 3.

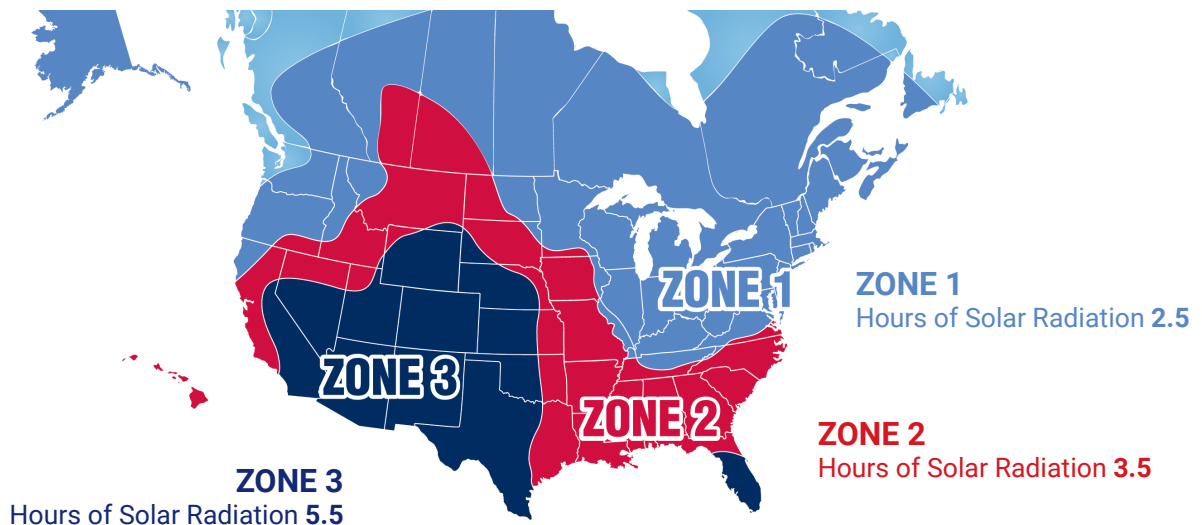

## 17 Connect Power Source to Battery Controller (DC Adapter or Solar Panel Kit)

The battery controller accepts inputs from either the DC transformer or the solar panel. The DC Adapter and solar panel come with a DC plug for easy installation. Once the power source is selected and installed connect the DC plug into the battery controller.



Charge Device plugs in here

## 18 Install Safety Signs

Install the 2 warning placards in the gate area where they are visible from the inside and outside of the gate. These are required per UL 325 to make persons aware of the possible danger of an automated gate.



## 19 Connect Linear Actuator Cable to Control Board

Before connecting the actuator cable to the control board check the following:

- Verify that all previous steps were performed.
- Verify that the battery connections are correct: red lead to positive and black lead to negative.
- Verify that nothing is in the path of the gate. If by chance it begins to move when power is applied, be prepared to disconnect the actuator cable.

### Patriot I (Single Gate)

- Locate the actuator cable and plug it into the Gate 1 actuator connector (see image) on the control board.

### Patriot II (Dual Gates)

- Locate the closest gate's actuator cable and plug it into the Gate 1 actuator connector (see image) on the control board.
- Locate the farthest gate's actuator cable and plug it into the Gate 2 actuator connector.

**Patriot II (Dual Gates)** with overlapping gates or electrical lock requiring gate delay. See step 24 on page 33.

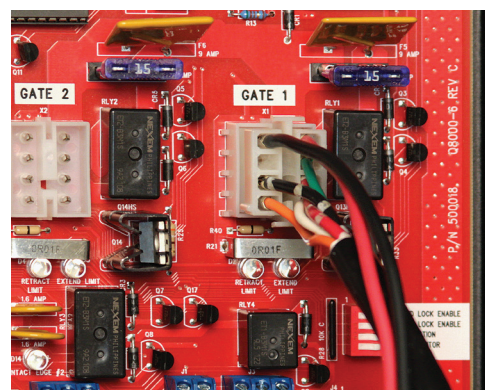

## 20 Photo Eye Alignment

With power now applied to the photo eyes, follow the alignment procedures outlined in the instruction booklet that is included with your photo eyes. Indicating lights assist with initial alignment. However, for optimal peak alignment follow the volt meter test instructions.

# 21 Operating Gate for the First time

Before operating the gate for the first time please verify the following items:

NOTE: This check must be performed before operating the gate for the first time. Failure to do so may damage the gate operator.

Before operating the gate lets make sure the Patriot control board dipswitches are set correctly for your installation. Locate the dipswitches on the Patriot control board.

Factory default dipswitch settings are 2 and 3 on.

*ON - Down on right*

*OFF - Down on left*

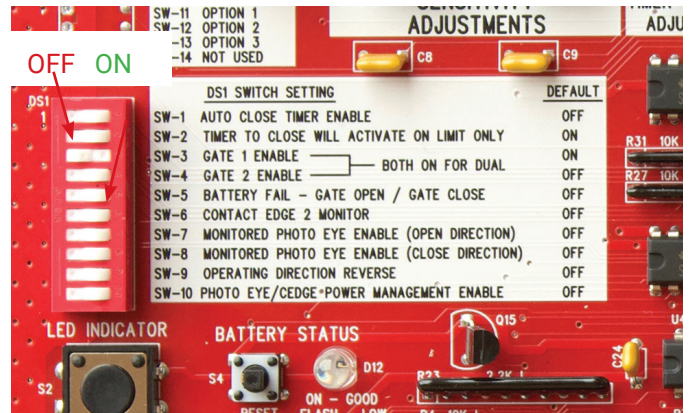

Identify your installation below and verify the standard dipswitch settings.

Closed Direction Monitored Photo Eye    Open Direction Monitored Photo Eye    W/ Monitored Contact Edge #1    W/ Monitored Contact Edge #2

			Closed Direction Monitored Photo Eye	Open Direction Monitored Photo Eye	W/ Monitored Contact Edge #1	W/ Monitored Contact Edge #2
<b>PATRIOT I</b>	(PULL TO OPEN)	Dipswitches 2, 3 should be in the ON position	DS1 switch 8 and 10 ON	DS1 switch 7 and 10 ON	DS2 switch 4 ON	DS1 switch 6 ON
<b>PATRIOT I</b>	(PUSH TO OPEN)	Dipswitches 2, 3, 9 should be in the ON position	DS1 switch 8 and 10 ON	DS1 switch 7 and 10 ON	DS2 switch 4 ON	DS1 switch 6 ON
<b>PATRIOT II</b>	(PULL TO OPEN)	Dipswitches 2, 3, 4 should be in the ON position	DS1 switch 8 and 10 ON	DS1 switch 7 and 10 ON	DS2 switch 4 ON	DS1 switch 6 ON
<b>PATRIOT II</b>	(PUSH TO OPEN)	Dipswitches 2, 3, 4, 9 should be in the ON position	DS1 switch 8 and 10 ON	DS1 switch 7 and 10 ON	DS2 switch 4 ON	DS1 switch 6 ON

1. Verify that linear actuator is connected to the gate bracket.
2. Press LED indicator and verify that the retract limit light is ON. If dual gate check both.
3. Locate the Open / Close command button on the Patriot control board. This button will start the gate when pressed once; pressing it again will stop the gate.
4. Press and release the Open / Close button. The linear actuator should begin to extend. Allow the gate to travel to the factory adjusted extend position. The gate should typically stop short of the desired extended position.
5. Press and release the Open / Close button again. The linear actuator should begin to retract. Allow the gate to travel to the factory adjusted retract position. The gate should typically be very close to the desired retracted position.

## 22 Making Retract and Extend Limit Adjustments

The independent retract and extend limit adjustments are located on the bottom side of the linear actuator. These will need to be adjusted. Remove the dust plug to make adjustments. A flat blade screwdriver is included with the operator for adjustment purposes.

**Caution: Do not use a battery powered screw driver to make these adjustments or damage to the limit assembly may occur.**

To increase the extend distance of the extension tube turn the extend screw clockwise.

To decrease the extend distance of the extension tube turn the extend screw counterclockwise.

To increase the retract distance of the extension tube turn the retract screw clockwise.

To decrease the retract distance of the extension tube turn the retract screw counterclockwise.

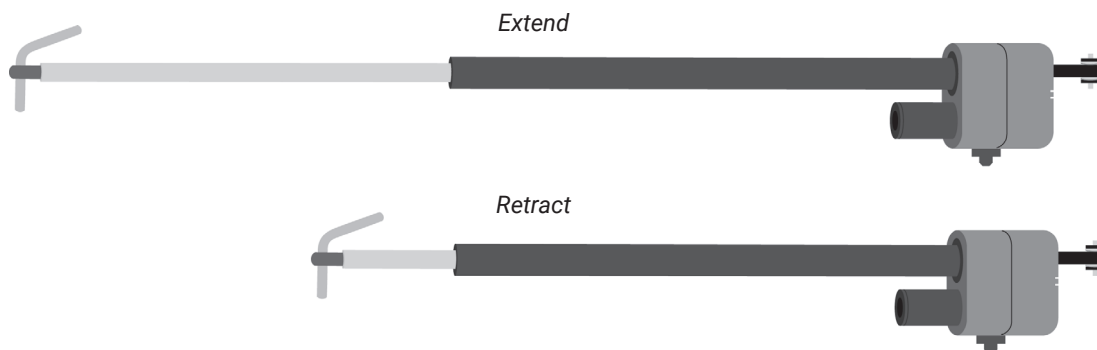
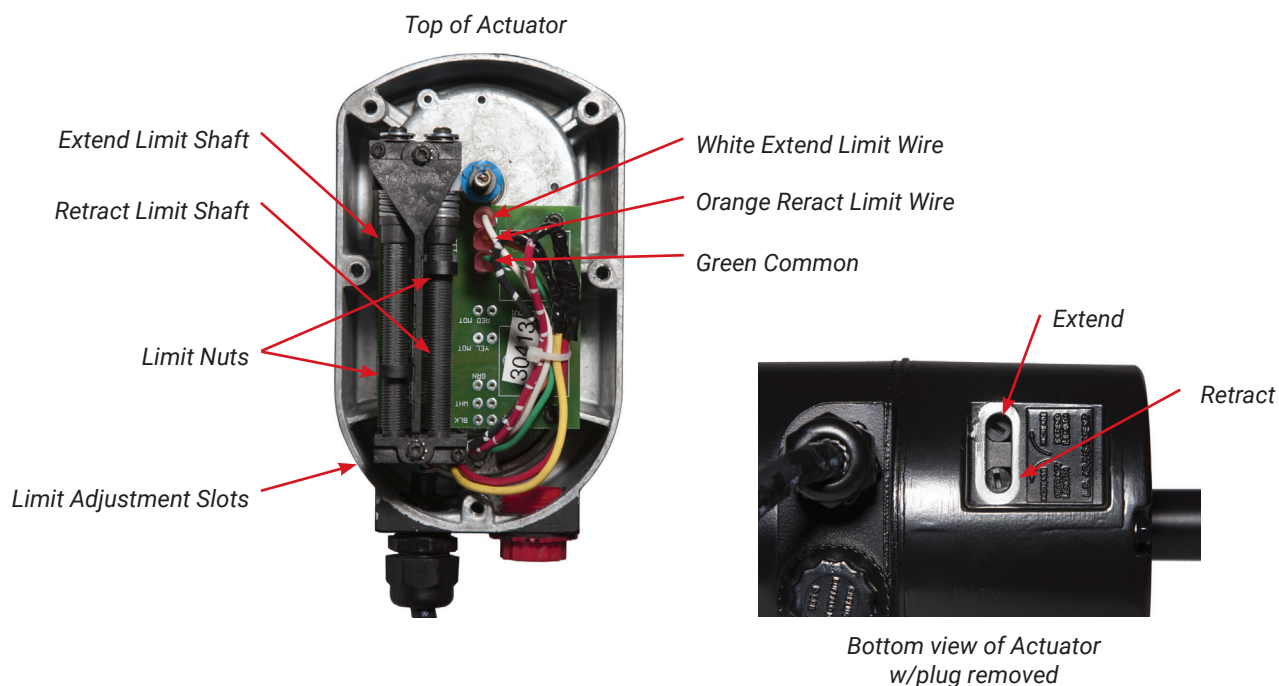

## 23 PWM Adaptive Soft Start / Stop Speed Control Adjustment

The control board is equipped with adaptive adjustable PWM soft start / stop speed control. The factory preset speed is set at a value of 4. Depending on the installation a different speed setting might be needed.

DS4 dip switches 1 - 3 control the soft start / stop speed.

The speed may be adjusted from a setting of 0-7. Each of the 3 switches represent a binary value and the switches turned ON add together for a speed setting.

**switch 1 - value = 1          switch 2 - value = 2          switch 3 - value = 4**

Looking at the picture you see the default speed value is set at 4 (DS4 switch 3 is ON)

If all 3 switches were turned OFF the value would = 0 (max speed)

If switch 1 and 3 were turned ON the value would = 5

If switch 2 and 3 were turned ON the value would = 6

If switch 1, 2, 3 were turned ON the value would = 7 (slowest speed)

The higher the value the slower the speed.

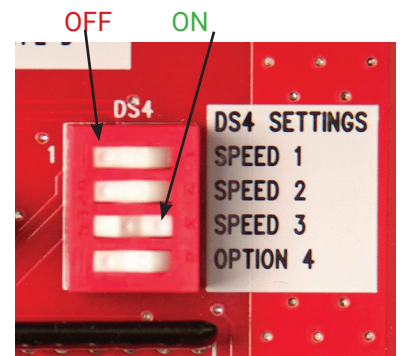

Avoid setting the speed value to a very slow speed, which would cause the motor to stall.

After speed value is changed wait 5 seconds before operating to allow new setting to be stored. The adaptive circuit will adjust the soft start / stop speed gradually to ensure proper gate operation based on the speed value selected.

### DS4 DIP SWITCHES

Switch		Setting	Factory Settings are shown in bold type
1	Soft Start / Stop Speed Control Value 1	ON	Speed value of 1 added
		OFF	<b>No speed value added</b>
2	Soft Start / Stop Speed Control Value 2	ON	Speed value of 2 added
		OFF	<b>No speed value added</b>
3	Soft Start / Stop Speed Control Value 4	ON	<b>Speed value of 4 added</b>
		OFF	No speed value added
4	Option 4	ON	NA
		OFF	NA

## 24 Gate Delay Feature - For Bi-parting Dual Gate Systems with overlapping gates and/or electric gate locks.

It is necessary to activate the gate delay feature anytime dual gates overlap in the closed position or have an electric gate lock. To activate this feature simply turn DS2 switch 1 on. The actuator plugged into Gate 2 will always open 2 seconds after Gate 1 opens and will always close 2 seconds before Gate 1 closes.

## 25 Sensitivity Adjustment, Entrapment Alarm, and Auto Close Setting

The Patriot control board has 2 sensitivity adjustment dials located in the upper left corner of the control board. These adjustments control the amount of current the control board will allow the motor to draw from the battery to operate your gate. Minimum force is the least amount of current allowed. This circuit is inactive for the first second of gate operation.

A typical adjustment setting is between 4 to 7 on the adjustment dial. If a setting above 8 is required for proper operation without just cause, you should check the gate, gate hinges or linear actuator for possible problems.

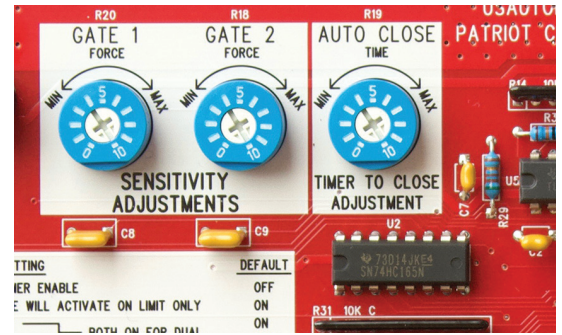

Both sensitivity settings should be individually adjusted on dual gate systems. On single gate systems, adjust the setting for the actuator plug being utilized (Gate 1 or Gate 2) and then match the setting on the other sensitivity adjustment.

### Entrapment alarm:

The entrapment alarm installed gives an audible alert whenever the gate sensitivity feature is activated twice before gate reaches an open or close limit. See chart step 26 for operation. Also used for low battery audible notification.

### Auto Close Setting:

**Important:** Auto close should not be utilized unless safety devices are installed to prevent automatic operation in case an object is in the path of the gate.

The adjustment dial controls the auto close time from approximately 2 seconds to 150 seconds. A setting of 0 will be the fastest auto close time.

## 26 Verifying Inherent Entrapment Protection System (Type A) Operation:

Once the gate operator is installed use the table below to determine correct operation.

It is recommended that the current sensitivity adjustment for the gate being tested be set at a setting no greater than 5 for this test.

Gate Opening - Gate is stopped by an object after 1 second of operation	Gate Closing - Gate is stopped first time by an object after 1 second of operation
<ul style="list-style-type: none"> <li>Gate stops and reverses for ~ 2 seconds.</li> <li>Auto close if turned ON is disabled.</li> <li>Requires a Push Button, Close, Open or Reset input before normal operation resumes.</li> </ul>	<ul style="list-style-type: none"> <li>Gate stops and reverses to full open.</li> <li>Auto close if turned ON is disabled.</li> <li>Requires a Push Button, Close, Open or Reset input before normal operation resumes.</li> </ul>
Gate Closing after above obstruction – If Gate is stopped a second Time Before Reaching the Close Limit	Gate Opening after above obstruction – If Gate is stopped a second Time Before Reaching the Open Limit
<ul style="list-style-type: none"> <li>Gate stops.</li> <li>Alarm sounds for 5 minutes until Reset is pressed.</li> <li>Requires a Reset input before normal operation resumes.</li> </ul>	<ul style="list-style-type: none"> <li>Gate stops.</li> <li>Alarm sounds for 5 minutes until Reset is pressed.</li> <li>Requires a Reset input before normal operation resumes.</li> </ul>

## 26a Verifying Monitored Photo Eye (Type B1) Entrapment device Operation Only:

Operate the gate and verify entrapment protection devices are working properly.  
Use the table below to determine correct operation.

<b>Type B1 - Photo Eye 2<sup>nd</sup> Entrapment - N/C input J2 pin 4 - Open Direction</b> If DS1 switch 7 is OFF this input is ignored. If ON, functions as described below	<b>Type B1 - Photo Eye 2<sup>nd</sup> Entrapment - N/C input J2 pin 8 - Closed Direction</b> If DS1 switch 8 is OFF this input is ignored. If ON, functions as described below
<b>Gate Opening Photo Eye Activated</b>	<b>Gate Closing Photo Eye Activated</b>
Gate stops	Gate stops and reverses to full open
Auto close if turned ON is still active	Auto close if turned ON is still active
Return to normal operation when the sensor is no longer activated.	Return to normal operation when the sensor is no longer activated.

## 26b Verifying Monitored Contact Edge (Type B2) Entrapment device Operation Only:

<b>Contact Edge (Type B2) Monitored Entrapment N/O input #1 J2 pin 6 OR #2 J7 pin 3</b> Dipswitch for input being used must be ON or gate will not move. If ON, functions as described below.	
<b>Gate Opening Edge Activated 1<sup>st</sup> time</b>	<b>Gate Closing Contact Edge Activated 1<sup>st</sup> Time</b>
Gate stops and reverses for ~ 2 seconds	Gate stops and reverses to full open
Auto close disabled	Auto close if turned ON is not active
Requires a Push Button, Close or Open input before normal operation resumes.	<b>If while opening after reversal above, a 2<sup>nd</sup> sequential input is received, gate must stop</b>
<b>If while closing after reversal above a 2<sup>nd</sup> activation occurs before the 2 seconds then</b>	Requires a Push Button, Close or Open input before normal operation resumes.
Gate stops	<b>Gate Closing Edge Activated 2<sup>nd</sup> Time before the close limit then</b>
Auto close disabled	Gate stops
Requires a Push Button, Close or Open input before normal operation resumes.	Auto close disabled
	Requires a Push Button, Close or Open input before normal operation resumes.

## 26c Verifying Constant Pressure (Type D) Operation Only:

**IMPORTANT:** Verify the gate path is clear before pressing the S5 button.

The S4 push Button (N/O) requires constant pressure to operate gate. When pressed and held the gate will run until the limit is reached or the button is released. If the button is released in mid travel the gate will stop and the next press of the button will run the gate in the opposite direction.

IF gate is closed and emergency switch is activated the gate will open and remain open until deactivated.



# 27 Patriot Control Board Information

The Patriot control board is capable of operating two gates. If your installation is a single gate you can operate the gate on the Gate 1 or Gate 2 connector. Set DS1 dipswitch "ON" for the connector being used.

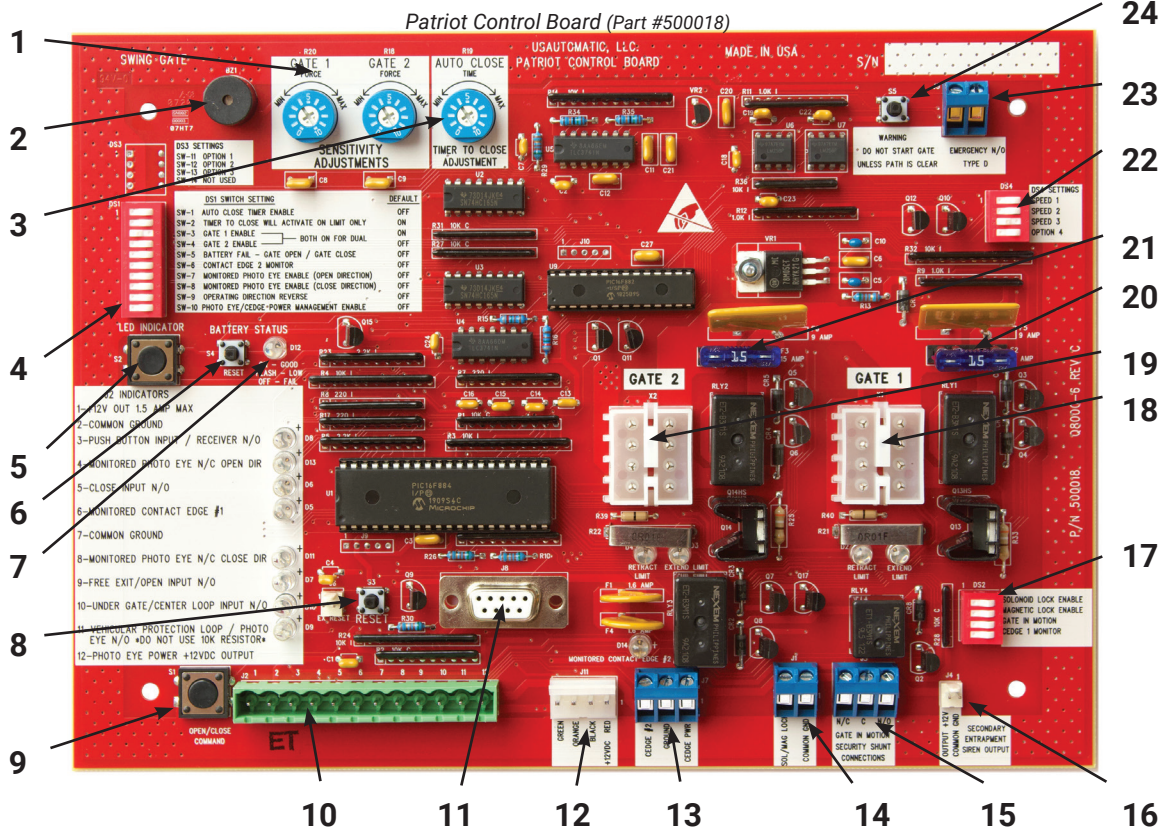

1	Sensitivity Adjustments	13	J7 - Contact Edge #2. Monitored Entrapment and Wireless Edge 12v power
2	Entrapment Siren	14	J1 Solenoid Lock / Mag Lock Output
3	Timer to Close Delay Adjustment	15	J3 Gate N Motion / Security Shunt
4	DS1 Dip Switches	16	J4 Entrapment Siren
5	LED Indicator Button	17	DS2 Function Dip Switches
6	S4 Battery Reset button	18	Gate 1 Plug
7	Battery Status LED	19	Gate 2 Plug
8	S3 System Reset	20	15 Amp Fuse Gate 1
9	S1 Open/Close Button	21	15 Amp Fuse Gate 2
10	J2 Terminal	22	DS4 Dip Switches - Speed Control
11	J8 App Plug	23	Emergency Type D Terminal
12	J11 LCR receiver Plug	24	S5 Type D button

## J2 Terminal Description

The accessory connector is a plug which can be removed from the control board for ease of wiring and troubleshooting purposes.

Place finger below connector and pull out to remove.

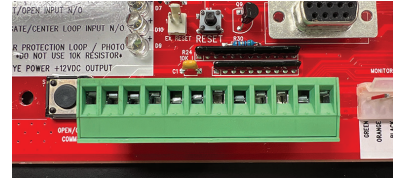

J2 Terminal

Terminal	
1	+12 vdc Output <i>(Maximum current output 1.5 amp - 1500 milliamps)</i>
2	Common Ground Input
3	Push Button Input <i>(normally open contacts)</i> <i>(Push button, radio control, keypad, etc.)</i>
4	PhotoEye Open Direction N/C Input <i>DS1 Switch 7 must be on. No 10K resistor.</i>
5	Close Input <i>(normally open contacts)</i>
6	Contact Edge #1 N/O connection monitored entrapment <i>DS2 switch 4 must be ON when monitored edge is connected</i>
7	Common Ground Input
8	PhotoEye Closed Direction N/C Input <i>DS1 Switch 8 must be on. No 10K resistor.</i>
9	Free Exit / Open Input <i>(normally open contacts)</i> <i>Loop input or any hold open input such as a 7-day timer, telephone access unit, or maintain contact switch (normally open contacts). These devices open the gate and will prevent the gate from closing if the contact is maintained. Once the contacts have been released, the gate can be closed with a closed signal device or the automatic close timer feature. Receiver relay2 pre-wired for latching open.</i>
10	Center Loop or Under Gate Loop Input <i>(normally open contacts)</i>
11	Safety Loop / Photo-eye / Reversing Edge Input used for vehicular protection devices. <i>(normally open contacts) *NO 10K DEVICES</i>
12	Photo Eye Power +12 vdc output 1 amp max current <i>Only present when DS1 switch 10 is ON and gate is moving or DS1 switch 3 and 4 are OFF and DS1 switch 10 is ON used for installation.</i>

# DS1 Function Dip Switches

ON - Down on right

OFF - Down on left

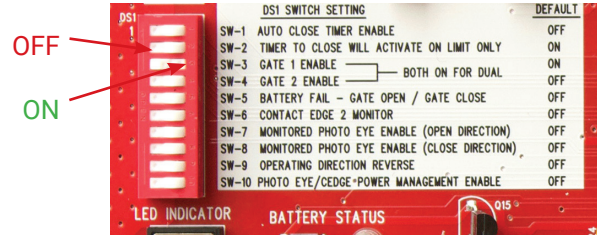

Switch		Setting	Factory Settings are shown in bold type
1	Automatic Close Timer Enable <i>(Not recommended unless safety devices are installed)</i>	ON	Timer to close is activated
		OFF	<b>Timer to close is disabled</b>
2	Timer to Close Function	ON	<b>Timer to close activates only if open limit is activated</b>
		OFF	Timer to close works from any point the gate is stopped
3	Gate 1 Enable	ON	<b>Gate 1 operator enabled to function</b>
		OFF	Gate 1 operator disabled
4	Gate 2 Enable <i>(both gates on for dual)</i>	ON	Gate 2 operator enabled to function
		OFF	<b>Gate 2 operator disabled</b>
5	Battery Fail <i>If battery voltage falls below 10vdc during a gate cycle the gate will travel to the selected position and shut down.</i>	ON	<b>Gate shuts down in Closed Position</b>
		OFF	Gate shuts down in open position
6	Contact Edge # 2 Monitor <i>Must be On if monitored contact edge is wired to J7 pin3</i>	ON	Monitored contact edge is installed J7 pin 3. Contact Edge must have 8.25K or 10K resistor.
		OFF	<b>No monitored contact edge installed</b>
7	Photo Eye Open Only N/C Monitored Entrapment	ON	Monitor Photo Eye open direction only
		OFF	<b>No monitored Photo Eye open direction installed</b>
8	Photo Eye Closed Only N/C Monitored Entrapment	ON	Monitor Photo Eye closed direction only
		OFF	<b>No monitored Photo Eye closed direction installed</b>
9	Operating Direction Reverse <i>(Must be on for push to open installations to operate correctly)</i>	ON	Push to Open
		OFF	<b>Pull to Open</b>
10	Photo Eye / Contact Edge Power Management Enable <i>*when ON 12 vdc will be present at J2 pin 12 whenever gate is in motion.</i>	ON	Enables PEPM
		OFF	<b>Disables PEPM</b>

## DS2 Function Dip Switches

ON - Down on right

OFF - Down on left

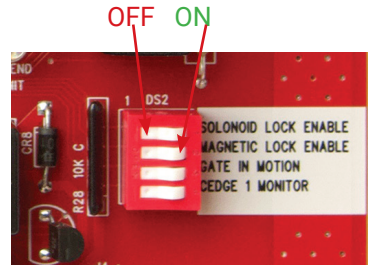

DS2 Switches

Switch		Setting	Factory Settings are shown in bold type
<b>1</b>	Solenoid Lock Enable / Gate in Operation Indicator / Gate Leaf Delay	ON	Solenoid lock output energizes half second before gate begins to move and releases 3 seconds after the gate begins to move.  For gate in operation indicator to operate DS1 SW 5 must also be ON. (Energizes = +12 vdc output 1.5 amp max/ / Gate leaf delay/gate 2 delays 2 seconds)  Gate Leaf Delay
		OFF	<b>Solenoid lock / gate in operation indicator / gate leaf delay is inactive</b>
<b>2</b>	Magnetic Lock Enable	ON	Magnetic lock output energizes on Master Limit and releases half second before gate begins to open. (Energizes = +12 vdc output 1.5 amp max)
		OFF	<b>Magnetic lock output is inactive</b>
<b>3</b>	Gate N Motion / Security Shunt Circuit / Open Gate Indicator	ON	Security shunt circuit relay is active (closed circuit)(wire in parallel) Relay activates half second before gate begins to open and stays activated until 4 seconds after gate reaches a closed limit
		OFF	<b>Security shunt circuit relay is inactive (open circuit)</b>
<b>4</b>	Contact Edge #1 Monitor (must be ON if monitored contact edge is installed at J2 pin 6)	ON	Monitored contact edge is installed J2 pin 6 Contact Edge must have 8.25K or 10K resistor.
		OFF	<b>No monitored contact edge installed</b>

## 28 Programming Transmitter and Receiver

Operating frequency 433.92 MHz.

Receiver can store up to 42 unique transmitter dipswitch code settings.

### Transmitter Setup:

*(It is recommended that the dipswitch code be changed from the default factory setting)*

1. Open the battery compartment door and locate the dipswitches.
2. Change the dipswitches to the settings you prefer, record for future reference in the table below.

Switch Position	Switch 1	Switch 2	Switch 3	Switch 4	Switch 5	Switch 6	Switch 7	Switch 8	Switch 9
+									
0									
-									



### Transmitter Left Button to Receiver Programming: *(standard Open/Stop/Close function)*

1. Press and hold the left transmitter button down. Red light on transmitter should be on.
2. On the receiver, push the P1 push-button until the green LD light comes on.
3. Release both buttons. Transmitter left button to receiver programming is complete.

### 2. Programming Transmitter Right Button to Hold-Gate-Open:

*(Only if auto close timer is enabled)*

1. The 2-channel receiver allows for programming the P2 relay from momentary mode (default) to latching mode. Transmitter right button can be programmed to hold gate open, over-riding the auto-close feature if activated.
2. Press and hold the right transmitter button down. Red light on transmitter should be on.
3. Press the P2 push-button until the green LD light comes on.
4. Release both buttons. Transmitter right button to receiver programming is complete.
5. Press the P2 push-button until the green LD light comes on, then release. **Green LD light should be steady. If flashing latch mode is already set.**
6. If not flashing release P2 immediately and press P1 once.
7. Green LD light should be flashing. Latching mode is set.

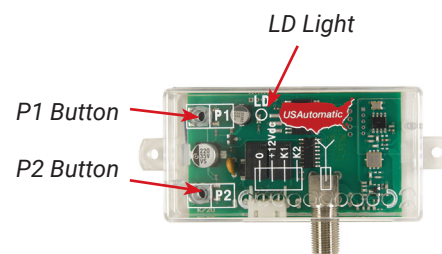

### Verifying Receiver P2 relay is programmed to latching mode:

1. Press the P2 push-button until the green LD light comes on, then release.
2. Green LD light should be flashing. If green LD light is steady, redo the Receiver Programming section above.

### Resetting receiver P2 relay to momentary mode:

1. Press the P2 push-button until the green LD light comes on, then release. Green LD light should be flashing.
2. While the LD light is flashing, push the P1 push-button down and release. Green LD light should be steady. Momentary mode is set.

### Erasing Single Transmitter from Receiver Memory:

The dipswitch settings of the transmitter to be deleted must be known. If known follow the steps below.

1. Set the dipswitches in a transmitter to match the switch settings of the transmitter code to delete.
2. Press and hold the left transmitter button.
3. On the receiver, push the P1 push-button until the green LD light comes on. Then release both.
4. Press and hold the right transmitter button.
5. On the receiver, push the P2 push-button until the green LD light comes on. Then release both.
6. Transmitter is now erased from receiver memory.

### Erasing all Transmitters from Receiver Memory:

1. Press the P2 button on the receiver until the green LD light comes on. Then release P2 button.
2. While LD light is on press the P1 and P2 buttons simultaneously and hold until the green LD light begins to blink slowly. It should blink 4 times then all transmitter codes are erased.

## Programming Your Wireless Keypad

**050500**

(plastic)

PUK code

---



**050551**

(premium metal)

PUK code

---



### Terms to Understand

**Access Code** – The 2 to 5-digit code used to open the gate (24 unique codes are possible). If access code is less than 5 digits it requires the # sign after code is entered. Example: “2 #.” If code is 5 digits the # sign is not required. Metal keypad uses A or B.

**ACCESS CODE CAN NOT BE THE SAME AS THE MASTER PASSWORD.**

**Master Password** – The 5-digit code used to access programming features. Factory default is “11111”. This should be changed for security reasons.

**NOT USED TO OPEN GATE AND CAN NOT BE THE SAME AS THE ACCESS CODE.**

**Relay 1** – The receiver has 2 relays. P1 (relay 1) is pre-wired to the J2 connector - pin 3.

**Relay 2** – The receiver has 2 relays. P2 (relay 2) is pre-wired to the J2 connector - pin 9.

**Keypad Security Code (Dip Switch Code)** – This code makes your keypad unique to your installation.

Keypad does not have dip switches like the transmitter; instead it has virtual dip switches which must be programmed.

**PUK Code** – “Password Unblocking Key.” The PUK code is located inside the keypad and is needed when the master password has been lost. Record in space above for future reference. Must be 5 digits long.

**“ \* ” or “A” Key** – located on the keypad is used to cancel last command entered.

**Red Light Blinks** – When blinking, the keypad is sending a signal to the receiver. Valid access code was entered. This is the Blue 5 key on the metal keypad.

**NOTE: Do not install keypad until “Create Communication with Receiver P1 (relay 1)” has been completed.**



## Keypad Programming

**Create Access Code:** (Code you use to operate the gate)

**\*CAN NOT BE THE SAME AS THE MASTER PASSWORD!**

1. Enter the Master Password "11111". (this is the factory default master password).
2. Enter "9" If correct, 2 short beeps (if 1 long beep is heard, start over with step 1).
3. Enter the new Access Code (up to 5 digits), if less than 5 digits, "# or B" key is required.
4. Enter "9"
5. Enter the new Access Code again to verify.
6. Enter "1". If this access code is for P1 (relay 1) Enter "2" if this access code is for P2 (relay 2).
7. If correct, 2 short beeps (if 1 long beep is heard, start over with step 1).
8. Continue with "Create Communication with Receiver" to complete programming.

**NOTE:** Step 6 above allows you to select a unique frequency (1, 2, 3, 4) for the access code you are creating. Keypad can be programmed with 4 different access codes each having a unique frequency. This is used when multiple gates are within range of the keypad. Create an access code using 1 in step 6 for one gate. Create an access code using 2 in step 6 for the second gate. This allows one keypad programmed with 2 access codes to operate 2 different gates within range or two keypads can be installed on 2 different gates without interfering with each other. If 4 gates were involved then 3 and 4 could be used in step 6. Also used to create a unique access code to activate the hold open feature offered with P2 (relay 2).

**Create Communication with Receiver: \*for P1 (relay 1) access code:**

1. Carry keypad to receiver location for programming.
2. Enter Access Code for P1 (relay 1) on the keypad and continue to press the last key entered (red light blinks).
3. Press P1 (learn button) on the receiver until LD (green light) comes on and relay clicks.

Receiver

P1 Button

P2 Button

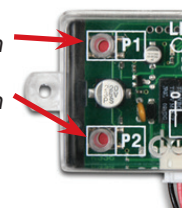

**Create Communication with Receiver: \*for P2 (relay 2) access code:**

1. Carry keypad to receiver location for programming.
2. Enter Access Code for P2 (relay 2) on the keypad and continue to press the last key entered (red light blinks).
3. Press P2 (learn button) on the receiver until LD (green light) comes on and relay clicks.

**Programming New Master Password: Once created record here for reference \_\_\_\_\_**

**NOTE: The Master Password is NOT an access code. This is a MASTER programming code used to access the programming of the keypad. It is not used to operate the gate.**

1. Enter the Master Password "11111".
2. Enter "8" If correct, 2 short beeps (if 1 long beep is heard, start over with step 1).
3. Enter the Master Password (up to 5 digits), if less than 5 digits, "# or B" is required.
4. Enter "8"
5. Enter the Master Password again to verify.
6. Press "8" If correct, 2 short beeps - New Master Password is set (If 1 long beep is heard, start over with step 1).

**Programming Master Password Back to Factory Default: (11111)**

1. Enter "11111".
2. Press "8" (long beep).
3. Enter PUK code. (PUK must be 5 digits).
4. Press "8".
5. Enter PUK code to confirm.
6. Press "8" (2 beeps) Master password reset complete.

### Deleting Single Access Code:

1. Enter the Master Password.
2. Press the "7" key. If correct, 2 short beeps (if 1 long beep is heard, start over with step 1).
3. Enter the Access Code to be deleted.
4. Press the "7" key.
5. Reenter the Access Code to be deleted.
6. Press the "7" key. If correct, 2 short beeps (if 1 long beep is heard, start over with step 1).

### Deleting All Access Codes:

1. Enter the Master Password.
2. Press the "7" key. If correct, 2 short beeps (if 1 long beep is heard, start over with step 1).
3. Reenter the Master Password.
4. Press the "7" key.
5. Reenter the Master Password.
6. Press the "7" key. If correct, 2 short beeps (if 1 long beep is heard, start over with step 1).

## Changing Keypad Security Code:

This keypad has a virtual dipswitch used to create your Security Code. The virtual dipswitch contains nine 3-position switches. To ensure neighboring keypads do not interfere with each other, the virtual switches should be positioned in a random pattern, using the following procedure.

Example of random positioning of the virtual dipswitches to create a Security Code is shown below. To enter the Security Code, enter the dipswitch number, followed by the dipswitch position character.

The Security Code would be entered as: 1# 20 3\* 4\* 5# 6\* 7# 80 9\*

Dipswitch Position	Switch 1	Switch 2	Switch 3	Switch 4	Switch 5	Switch 6	Switch 7	Switch 8	Switch 9
# or B	X				X		X		
0		X						X	
* or A			X	X		X			X

Use table below to create your random security code and follow steps below to program your keypad.

Dipswitch Position	Switch 1	Switch 2	Switch 3	Switch 4	Switch 5	Switch 6	Switch 7	Switch 8	Switch 9
# or B									
0									
* or A									

1. Enter the Master Password.
2. Enter "6" If correct, 2 short beeps (if 1 long beep is heard, start over with step 1).
3. Enter the Security Code created in the previous table. If correct, 2 short beeps after each switch number and switch position combination is entered.
4. Enter "# or B"
5. Enter "6"
6. If correct, 2 short beeps (if 1 long beep is heard, start over with step 1).



# PERIODIC SERVICE

All gate operators require periodic checking and adjustments of the control mechanism for force (load), speed and sensitivity. These checks should be made by a qualified technician to verify proper adjustment and operation of all safety related components including those mentioned above.

All accessories and monitored safety devices must be checked. Monitored entrapment protection devices need to be checked at least once a month for proper operation.

Periodic checking is also advised for the following:

1. Battery terminals for corrosion.
2. Hinges, pivot points and emergency release pin need to be greased.
3. Mounting bolts for correct tightness.
4. Inspect weld points for cracks or other defects.
5. Inspect wiring for cuts, nicks or other defects.
6. Inspect hinge post to ensure it is not moving or twisting.
7. Verify battery voltage by looking at the Battery Controller. Voltage should be above 12 Vdc.
8. Verify monthly that the inside of the control cabinet remains clean and free of insects. Do not spray control board with bug spray or oil based products.
9. Opening or closing time should be approximately 12 seconds. If the time begins to increase and the gate begins to slow down, the battery needs to be tested.
10. Inspect linear actuator cover tube seal where stainless extension tube exits the black cover tube for deformation or cracking. Apply lubricant (grease) to keep seal in good condition.

## Emergency Manual Release

**NOTE: Before detaching actuator arm from gate, turn DS1 dipswitch 3 and 4 to the OFF position (page 38). This will keep the actuator from operating while arm is disconnected from the gate.**

Remove the manual release pin at the gate bracket and open the gate by hand. Secure the gate before attempting to pass through.

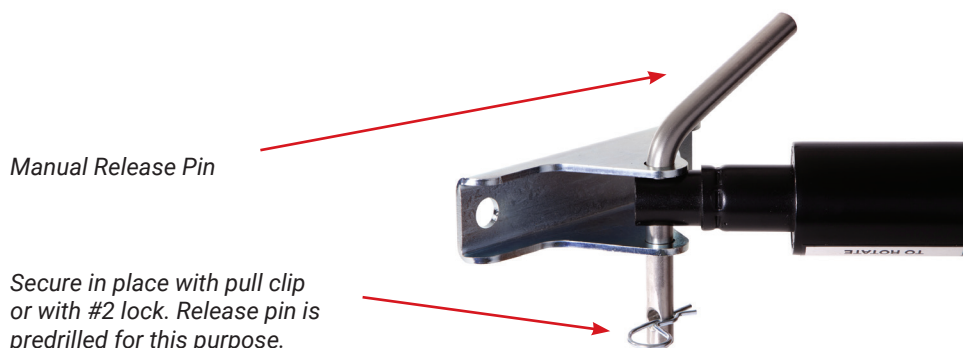

## USAutomatic Gate App Module

Part Number 030223

- Open/close gate operator
- Remote control via USAutomatic Gate App
- Works with Alexa and Google Assistant enabled devices
- Best-in-class encryption technology
- Compatible with USAutomatic Gate Operators



## CP-4 Free Exit Device (Solar friendly device)

Part Number 070305

The driveway exit sensor is a magnetic device that installs below ground beside the drive. A magnetic field is established which when interrupted by a moving metal object will send a signal to open the gate. This sensor is supplied with 100 foot of cable and is typically installed inside the property beside the drive to automatically open the gate when a car passes. This type of sensor is not a safety device.



## LCR Wireless Push to Operate Button

Part Number 030215

The Push to Operate transmitter is designed for indoor or outdoor wireless installation. Install to allow operation of the gate by simply pressing the pad. The button is a pressure sensitive pad. Press the pad and an audible tone is generated. Programming is identical to transmitter programming. Installation hardware is included. Compatible with all USAutomatic receivers.



## LCR 2 Button or 4 Button Basic Transmitter

2 Button Part Number 030210

4 Button Part Number 030212

- Standard Transmitter for all USAutomatic operators
- Operating Frequency 433.92 MHz



## LCR 2 Button or 4 Button Premium Transmitter

2 Button Part Number 030217

4 Button Part Number 030218

- Fixed or clone programmable
- Operating Frequency 433.92 MHz



## LCR Basic Wireless Keypad

Part Number 050500

- Operating Frequency 433.92 Mhz
- 2 to 5 digit Access Codes
- Capable of storing 1 to 24 different access codes
- Access code can be programmed to either primary relay 1 or secondary relay 2.



## LCR Premium Metal Wireless Keypad

Part Number 050551

- Rugged die-cast locking aluminum cover
- Up to 256 2-5 digit access codes and 256 temporary access codes
- Hold open access code
- Battery included or 12/24 VAC/DC external supply selectable
- Tamper lock out for 60 seconds after 7 incorrect access codes



## Premium Metal Hardwired Keypad

Part Number 050700

- Rugged die-cast locking aluminum cover
- Up to 1000 permanent or temporary 2-5 digit access codes
- Stainless steel, blue LED backlit keypad
- 2 relays capable of operating for timed activation of 1-99 seconds or for hold open latch mode
- Tamper lock out for 60 seconds after 7 incorrect access codes
- Night light and illuminated keys can be programmed for full time on or only when keys are pressed



## 7 Day Timer (Solar friendly device)

Part Number 550015 (CR2032 Button Cell Battery Included)

- Easy to program
- 17 events per day
- Time displayed in 24 hour format
- 12VDC only



## Electric Gate Lock

Part Number 070510

**Suitable for solar and AC charged systems.**

The USAAutomatic Control Board will energize and release this 12 VDC electric gate lock 1 second before the gate or gates begin to open.



## Photo Eyes - BATTERY

Part Number 550011 (Wire Not Included)

- Battery powered emitter (Batteries Included)
- Eliminates wires across driveway to emitter
- Better reliability than reflector
- Input: 12V AC/DC or 24V AC/DC
- Range: 42 feet



## Metal Photo Eyes

Part Number 550014 (Wire Not Included)

- Rugged metal housing
- Eye rotates up to 180 degrees
- Input: 12V AC/DC or 24V AC/DC
- Range: 65 feet



## 20 Watt Solar Panel Kit

Part Number 520031

- 2 mounting brackets included
- DC power plug for easy connection



## Expansion Module Monitored Entrapment Device

Part Number 500015

The expansion module is designed to monitor for the connection and proper operation of multiple monitored external entrapment devices.

If the installation requires more than 1 monitored contact edge or 1 monitored photo eye for open or close direction, the expansion module must be installed.

Monitors up to 5 monitored contact edges (10K resistor) and up to 4 monitored photo eyes (N/C contact - NO 10K) for a total of 9 devices.



# TROUBLESHOOTING

The complete troubleshooting guide is available online which allows us to easily and quickly update the contents as required.

Scan the QR code here with your phone camera to access the troubleshooting information online. Or visit - [www.usautomatic.com/troubleshooting/patriot](http://www.usautomatic.com/troubleshooting/patriot)



## 1. LED indicating lights

These lights will help to identify problems with the actuator limit switches and all control circuits. To use the indicators, press and hold the "LED Indicator" button on the control board. (The LED's are not active unless the LED indicator push button is pressed and held to save battery life). Any circuits or limit switches that are activated will be obvious by the illumination of the adjacent LED.

## 2. Current sense beeper

The beeper will sound anytime the current sense circuit is activated. This is useful in detecting a false reverse due to an improper or too sensitive current reverse setting, or a gate, which is requiring excessive force to move

## 3. S5 push button - Type D protection

Type D button will bypass all entrapment devices allowing gate operation. Verify gate path is clear before pressing button. Must hold button for gate operation.

## 4. Battery status LED

- A. Solid Red - battery good
- B. Flashing Red - battery has fallen below 10.5 vdc while in operation - battery needs to be load tested.
- C. LED is OFF - battery has fallen below 10 vdc while in operation - battery needs to be load tested.

## 5. Low Battery Notification / Low Battery Shut Down

1. If the entrapment siren is beeping 3 times quickly then pausing for 5 seconds and repeating this for 60 seconds this indicates the battery has fallen below 10.5 vdc during a gate cycle. Remove battery and have it load tested and check the charging system for proper operation.
2. If the gate has shut down in the open or closed gate position it is possible that the battery has dropped below 10 vdc during a gate cycle. Gate will shut down in the selected position of DS1 switch 5. This can be verified by pressing the LED indicator button and observing the Battery Status LED. If fail condition exist remove battery and have it load tested to determine battery condition. If battery is good then charging system needs to be verified for proper operation.

## 6. Battery Reset

If gate is shut down and battery status LED is OFF when pressing the LED Indicator then press the Battery Reset button and hold for 7 seconds to reset. If gate now operates remove battery and have it load tested.

## Gate Fully Open and Close Stop Positions are Changing (not consistent).

**NOTE:** Verify that the open and close positions are both changing randomly, before following these steps.

1. Remove the five 5/16 bolts from the back of the actuator to expose the limit assembly.
2. Loosen the 4 screws that hold the limit assembly in place (see below)
3. Gently push the limit assembly over reducing the spacing between the small white gear and the blue gear (see below)
4. While holding the limit assembly in place tighten the 4 screws.
5. Reinstall the rear housing and adjust retract and extend limits to desired stop positions.

*Top of Actuator*

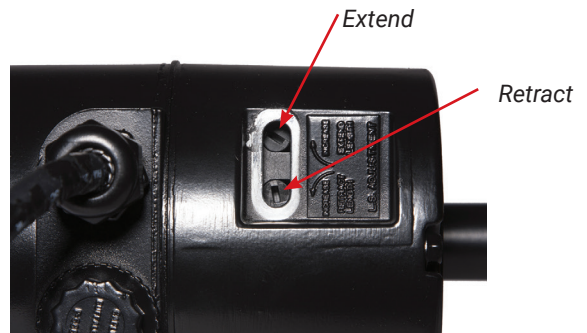
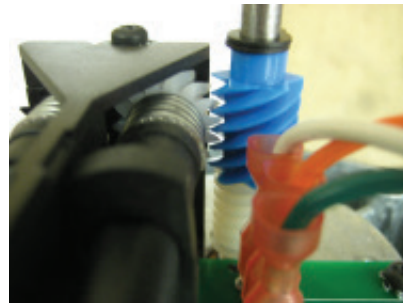
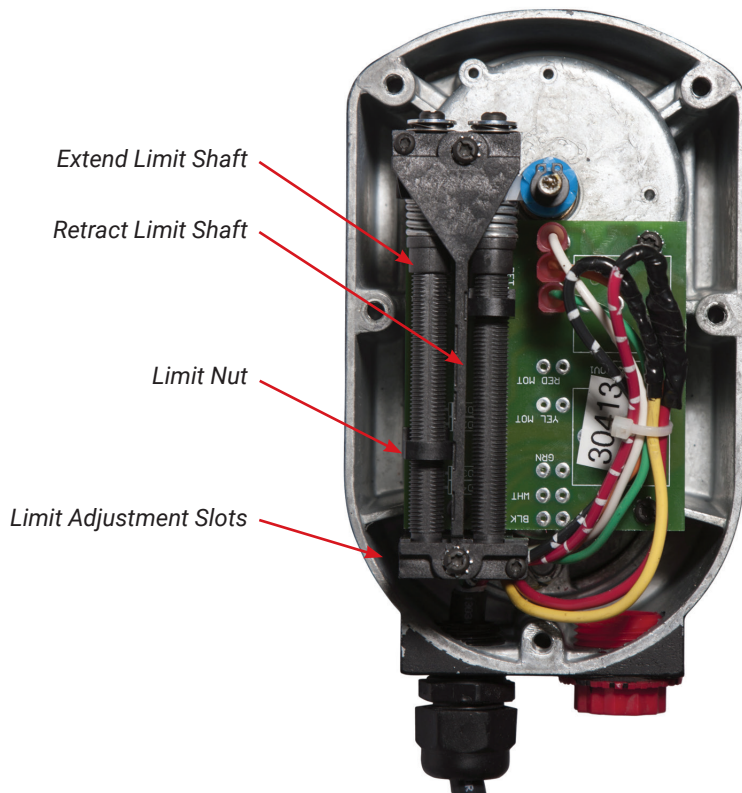

*Bottom view of Actuator  
w/plug removed*

## A Photo Eye - Vehicular Protection Only

Part Number 550011 - battery or hardwired transmitter  
 Part Number 550014 - hardwire only

Wiring Photo Eye to Patriot Control board  
 (Control Board part #500018)

Photo eyes are recommended for all systems. This provides protection against the gate closing on objects that may be in the gate path. Typically a swing gate needs two sets of photo eyes for the best area protection (see figure).

One set of photo eyes pointing across the drive on the outside of the hinge post (A). The second set mounted across the drive at the point where the gate is fully opened (B). The photo eye must be installed where the gate does not break the beam.

Vehicular Protection Shown Below - Entrapment Protection Must Protect Entrapment Areas page 3



#550011



#550014

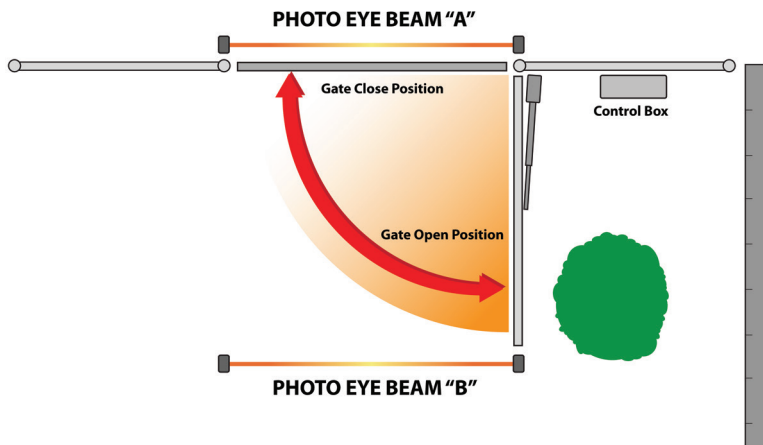

The primary unit (Receiver) should be installed close to the control box.

It requires 4 wires to be installed from the unit to the control box.

The second unit (Transmitter) can be hard wired or battery powered, if using part # 550011 and should be installed on the opposite side of the drive.

Hard wired Photo Eye (550011 or 550014) requires 2 wires to be installed from the unit to the control box.

The two units must face each other to establish the beam (maximum distance 40 feet).

When utilizing the PEPM software the photo eye will only be powered up when the gate is operating.

## Installing Photo Eye For Vehicular Protection Only - NOT MONITORED

The photo eye must be wired as shown and the correct dipswitches must be turned on for the PEPM software to work correctly. Detailed instructions and illustration shown below.

**NOTE:** Monitored Entrapment UL325 photo eye installation instructions refer to page 25 step 14a.

1. Connect photo eye power wire +12 vdc to J2 pin 12.
2. Connect photo eye power ground to J2 pin 2 or pin 7.
3. Wire the RX relay N/O contact from the photo eye to J2 pin 11. No 10k
4. Wire the RX relay common from the photo eye to J2 pin 2 or 7.
5. Turn OFF DS1 switch 3 and 4 (temporarily to provide power for installation)
6. Turn on dipswitch DS1 switch 10 photo eye power enable.
7. Install Photo eye and adjust beam – verify proper operation.
8. Once installed turn ON DS1 appropriate dipswitches for gate 1 or gate 2 or both for dual gates.

Test photo eye for proper operation, when gate is closing and beam is broken gate should stop and reverse to full open. If gate is open and beam is broken gate will not close.

**NOTE:** Power is applied to photo eye just before gate operation begins and turns off when gate stops.

**\*IMPORTANT - Photo Eye connecting to J2 pin 11 MUST NOT have a 10K resistor installed.**

### Closed Direction Wiring

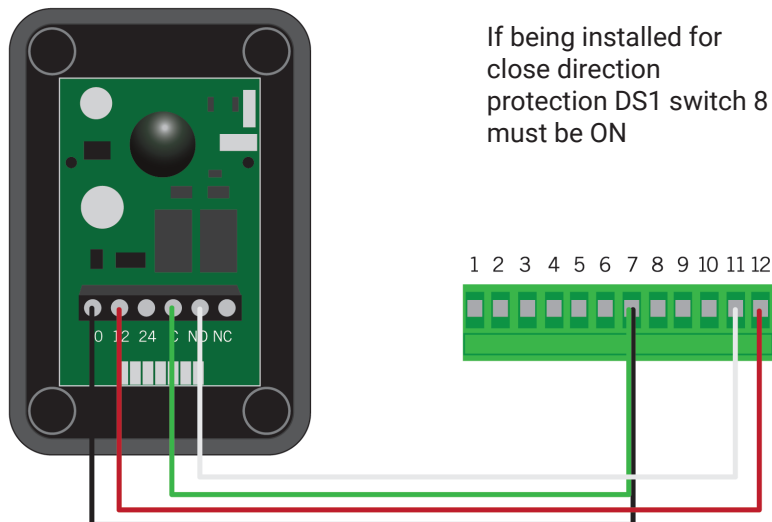

- Photo eye "0" connects to J2 green plug pin 7.
- Photo Eye "12" connects to J2 pin 12
- Photo Eye "C" connects to J2 pin 7
- Photo Eye "NO" connects to J2 pin 11

# B USAutomatic Battery Controller

Battery controller is designed to charge 12 vdc batteries of various types using either solar panel or DC transformer part # 520009. It also capable of charging 24 vdc battery if using a 24-volt solar panel. The package includes Power source input adapter plug.

**Recommend battery types:** SLA (Sealed Lead Acid), FLD (Flooded Lead Acid), GEL and AGM are all ideal choices. We do not recommend using Lithium-ion batteries with this controller.

Controller Features		
12 / 24 vdc battery detection	Charge current reading active	PWM charging mode
Battery reverse connection protection	Battery voltage reading active	USB power outlet
LCD display	Battery reverse discharge protection	Plug N Go connections
Controller Specifications		
10-amp solar charger	6.2 in x 2.9 in x 1.06 in	Weight 4.2 oz
DC adapter 20vdc @ 1.2 amps max	Float charging 13.8 / 27.6 vdc	Max solar panel 130 watts
Self-consumption < 9ma	USB max current 1.5 amps	Automatic cutoff under 10.8 vdc

## Installation

The controller is fully automatic for easy and quick installation.

1. Connect battery to the controller.
2. Controller LCD screen will display current battery voltage.
3. Connect Power Source to controller (solar panel or DC transformer)



### Power Source Inputs:

1. DC power plug 2.5mm
2. Direct wire leads 14-18 gauge

### Battery Connections:

1. Anderson Power Plug

## Operation

- Charging Indication Symbol when steady indicates that the power source is charging the battery.
- No symbol indicates power source is not supplying enough energy to charge.
- No symbol indicates power source polarity is reversed, verify power source polarity.

*\*If the symbol is flashing, the battery is fully charged and has entered float charging state.*

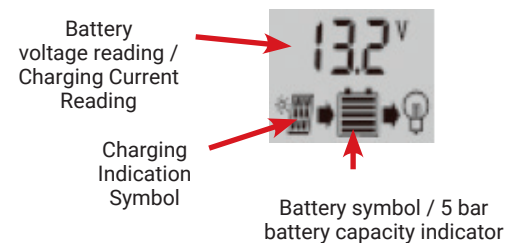

## Diagnostics

1. Controller LCD screen is blank:
  - A. Battery voltage below cutoff voltage. Load test battery replace or charge as necessary.
  - B. Reverse battery connection indication. Verify battery polarity connection to controller.
2. Battery symbol is flashing – indicates the battery voltage exceeds the rated input voltage of the charger. Disconnect the external battery charger from battery or choose appropriate battery.
3. E11, E12, E13 displayed – Battery needs to be removed, charged and load tested.

**Warning - Risk of explosion! Never install the controller in a sealed enclosure with flooded batteries.**



## WARRANTY\*

**USA Automatic LLC provides the following warranty from date of manufacture:**

- All operators shall be free from defects in materials for a period of 3 years
- Ranger 500 and Ranger HD control boards - current design – 3 year warranty
- Patriot and Patriot RSL control boards - current design – 5 year warranty
- Control boards - previous versions - 1 year warranty
- All accessories - 1 year warranty

This warranty excludes items that have been abused, misused, altered, incorrectly installed, damaged from battery acid, damaged by weather or other acts of God, or had lack of necessary maintenance. Changes or modifications not expressly approved by the Manufacturer will void the warranty.

This warranty is limited to the product only, no incidental or consequential damages are covered. Charges such as field labor and trip charges to inspect or reinstall a repaired or replaced unit are not covered. Replacement of battery is not covered. This warranty also does not cover any problems with the gate or gate hardware or any consequential damages to any surrounding area of the gates.

All warrantied products will be repaired or replaced at the discretion of the Manufacturer. All required parts, shop labor, and return shipping to our customer will be provided free of charge (within the contiguous United States).

## SUPPORT

If you have operational questions, or are in need of warranty service, please contact our Support Department by email at [support@usautomatic.com](mailto:support@usautomatic.com) or call 972-221-7000 Monday through Friday (or toll free at 888-204-0174).

If your issue is not resolvable, our Service Department may request the product(s) be returned for warranty service. A Return Authorization Number (RA#) will be issued and you will be given instructions on how and where to return the product. Packages without an RA# written on the box may not be accepted.

**We will need the following information:**

Model: \_\_\_\_\_ Serial Number\*\*: \_\_\_\_\_

Date of Purchase: \_\_\_\_/\_\_\_\_/\_\_\_\_ Purchased From: \_\_\_\_\_

\*You may have other rights based on your State. Please refer to State Law for specific inclusions and exclusions.

\*\*Serial Number can be found by opening operator cover and looking on the control board



USAAutomatic, LLC  
170 Valley Ridge Blvd  
Lewisville, Texas 75057

sales@usautomatic.com  
support@usautomatic.com

**972-221-7000 or 888-204-0174**

© USAAutomatic, LLC, 2025 Rev. A

All rights reserved. No part of this may be reproduced by any means without the expressed written consent of the publisher.



[www.usautomatic.com](http://www.usautomatic.com)

